

Private Automatic Branch Exchange 7 (PABX 7)

This automatic system meets the telephone requirements of organisations needing up to twenty exchange lines and one hundred extensions.

It offers internal telephone service and public exchange service on the same telephone.

A trim, desk-mounted, cordless switchboard is provided for the PABX operator.



Benefits

Time saving direct access by extensions to the public exchange network.

Quick and efficient internal communication.

A trim, desk-mounted, cordless switchboard in keeping with modern reception areas.

Extension telephones can directly connect internal as well as external calls.

Description

The PABX 7 can accommodate up to 20 exchange lines and 100 automatic extensions. Some manual extensions can be provided if required, with the appropriate reduction in automatic extensions. Private circuit or inter-switchboard extensions can also be arranged to most other types of automatic or manually-operated Private Branch Exchanges (PBXs).

The PABX operator receives incoming exchange calls on the desk-mounted switchboard (illustrated right) and assists the extensions as necessary.

The automatic equipment which is housed in two steel cabinets, together with other apparatus, may be sited in a suitable room near the switchboard.

The equipment is powered by a mains rectifier unit which also keeps the secondary-cell standby battery charged.

General facilities

A call can be made direct from one automatic extension to another, or to a manual extension, by dialling a three-digit number between 200 and 299, the range depending on the size of the installation.

Exchange calls can be made direct from automatic extensions by first dialling 9 for exchange line access.

If required, any automatic extension can be connected in such a way that it can only make an exchange call through the switchboard.

Timing of any outgoing exchange call stops as soon as the extension handset is replaced. This also releases the exchange line.

Incoming exchange calls are received on the switchboard and connected by the operator to the required extensions through the automatic equipment. These calls may also be extended by the operator over some inter-switchboard extension circuits to an operator or extension on a distant PBX.

Outgoing calls to one other PBX can be made direct from an automatic extension by first dialling either 5, 6 or 7. If additional equipment is provided it is possible to obtain up to six different PBXs by dialling 1, 3, 4, 5, 6 or 7.

It may be possible to dial direct to the extension of another PABX over an inter-PBX line. It is not possible, however, to interconnect other PBXs through the PABX 7.

Under certain conditions, additional inter-PBX or private circuits, to different destinations if required, can be connected in place of an equivalent number of extensions. They are obtained by dialling the appropriate extension numbers. Exchange calls can be extended over these circuits.



The PABX operator is called from an automatic extension by dialling 0.

All outgoing calls from manual extensions are made through the switchboard except during night service arrangements (see later). Incoming calls are received through the automatic equipment.

In the event of mains failure, service on the PABX can be maintained by the standby battery for several hours, subject to the load.

Switchboard facilities

The operator calls extensions from the switchboard by pushing buttons for the required number. Ringing is normally applied automatically to the extensions.

An audible calling alarm signal is provided at the switchboard by a tone caller which gives continuous single note. This can be switched off, if and when required, by the operator.

Calls to or from extensions are released automatically when the extension handset is replaced.

Ring-when-free is available if an extension is engaged. This means the PABX operator can let an exchange line caller hold on, to be connected automatically to the required extension as soon as it becomes free. More than one caller can hold for the same extension, but there is random selection for the first one to be connected.

The PABX operator can interrupt a call on an engaged extension to ask if another call can be accepted. A ticking sound (warn tone) lets the extension user know that the operator is on the line.

Exchange calls can be held at the switchboard simply by restoring the speak button. The calls can then be connected to extensions when required. When more than one call is held in this way, there is no overhearing.

Extension facilities

Calls between extensions are released when either extension handset is replaced.

On an exchange line call and some inter-PBX calls an automatic extension user can hold the exchange call and make an enquiry call to another extension by pressing the button on the telephone once and dialling the number. The user can return to the original exchange call by pressing the button again.

After making an enquiry call, the exchange call is transferred to the other extension, when the user replaces the handset.

Facilities outside normal hours (night service)

When the night service button on the switchboard is pressed, any incoming exchange call causes suitably sited bells to ring continuously until the call is answered.

Calls are answered by dialling 8 at any extension from which exchange calls can be made directly. The answering extension can transfer the calls to other extensions, if necessary.

Alternative methods can be provided which enables individual exchange lines to be connected to selected extensions, or one particular extension may be designated to answer calls.

Manual extensions can, if required, be given facilities for making calls automatically on night service.

General information

The switchboard is grey and olive green, with wooden ends. A Trimphone-type handset is normally provided for the operator, but this can be replaced by a lightweight headset, if preferred.

Dialling codes

- 1 – Spare
- 200-299 – For extensions
- 3 – Spare
- 4 – Spare
- 5, 6, 7 – To one other PBX, or three other PBXs if additional equipment is provided.
- 8 – For answering calls on night service.
- 9 – Exchange line access
- 0 – To call the PABX operator

Alarms

Audible and visual signals on the switchboard draw attention to incoming calls, mains failure and fault conditions.

The audible alarm is a tone-caller which can be switched off if necessary. It is also switched off when the night service facilities are in use.

Tones and Ringing

Dialling, ringing, engaged, 'warn' and number unobtainable tones are provided from the PABX equipment.

A distinctive form of ringing can be provided to signal incoming exchange calls, to distinguish them from extension to extension calls.

Accommodation

The automatic equipment is housed in two cabinets which, together with the battery, mains unit and distribution frame, are installed in a separate room near to the switchboard.

Sufficient space has to be left around the equipment for maintenance purposes. The cabinets have doors front and rear, so that the engineer can get at both sides of the equipment racks. In consequence, the room should be not less than 4000 mm by 3700 mm in area, and at least 2300 mm high.

Heating, lighting and ventilation to normal office standards should be provided.

Customers must provide an exclusive mains 3-pin socket outlet of at least 5-amp rating in the equipment room.

PABX 7 capacity

The capacity can only be increased beyond the limits shown, by replacing the unit with a different type of PABX.

| | |
|---|-----|
| Exchange lines | 20 |
| Reduced by one for each automatic or manual inter-PBX line, or manual extension provided. | |
| Automatic extensions | 100 |
| Reduced by one for each automatic inter-PBX line, or manual extension provided. | |
| Manual extensions | 4 |
| Inter-PBX circuits* | 20 |
| Connecting circuits | 12 |
| Enquiry transfer circuits | 2 |
| Operator assistance circuit | 1 |

*Note: refer to Exchange lines.

Dimensions and weights of equipment

| Equipment | Width | Depth | Height | Weight |
|------------------------|--------|-------|--------|--------|
| Cordless switchboard | 498mm | 260mm | 181mm* | 8 kg |
| Equipment cabinet | 935mm | 610mm | 1970mm | 499 kg |
| Equipment cabinet 2 | 1392mm | 610mm | 1970mm | 590 kg |
| Distribution frame | 340mm | 460mm | 1700mm | 45 kg |
| Mains rectifier unit | 300mm | 400mm | 600mm | 36 kg |
| Secondary cell battery | 1200mm | 388mm | 1382mm | 324 kg |

* Height includes plinth

Switchboard

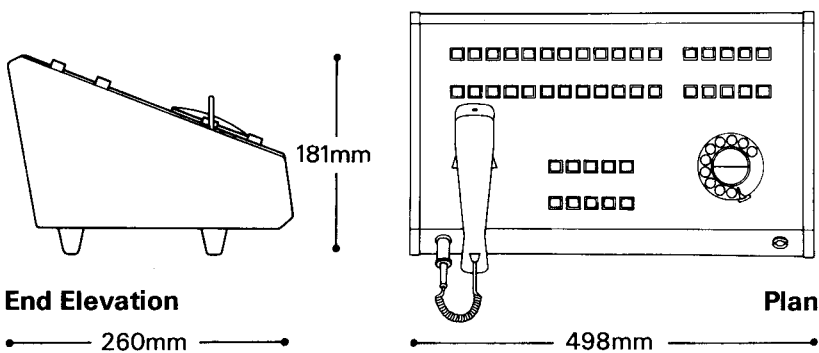

Typical floor plan of equipment for a PABX7

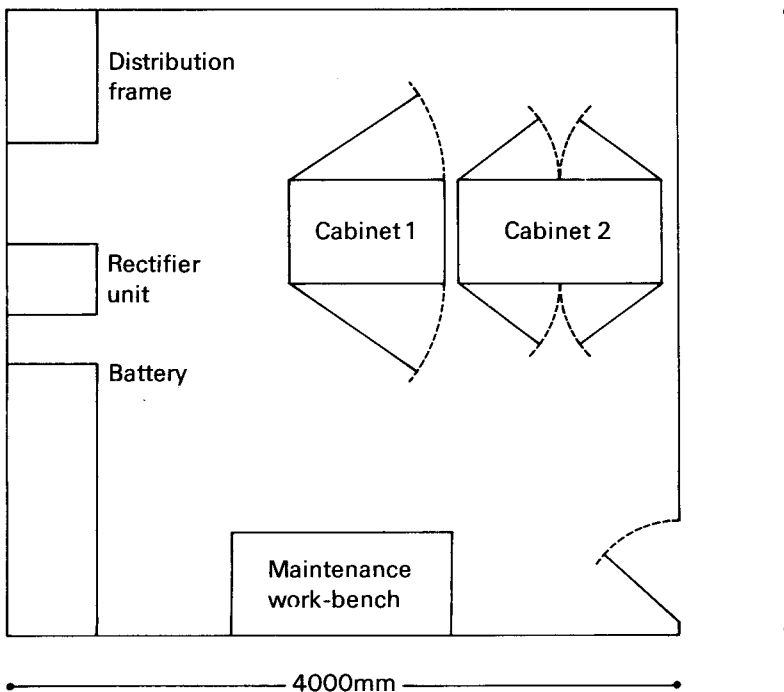

NOTE:
The floor plan shown is for a basic installation. Additional facilities may require extra accommodation.
Customers are advised to discuss equipment room requirements with their local Telephone Sales Office before planning PABX accommodation.

Please note

We do our best to supply our customers with the apparatus they ask for but we may have to provide apparatus which does not accord exactly with the descriptions, illustrations and shades of colours shown in this leaflet.

Your Telephone Sales Office will gladly supply any further information or details of any changes in the information in this leaflet since it went to print. The address, telex and telephone numbers are shown in the preface of your Telephone Directory. Information on a wide range of our services and apparatus is contained in the Green Pages section of most Telephone Directories.