

Console-mounted Teleprinter 15's

August 1972

Descriptive
Leaflet

DLG 704

Telex Service

The basic telex installation with Teleprinter 15 is fully described in DLG 702, and the Teleprinter 15 with automatic transmission facilities is explained in DLG 703.

Both types of installation can also be provided with the teleprinter mounted on a console which occupies less floor space than the normal desk-mounted installation.

The console model of the basic telex installation is shown below; the photographs overleaf show in detail the working area of each type of console-mounted teleprinter.





Arrangement of keys

The keyboard arrangement for each console model is identical to the corresponding desk-mounted installation.

The four control buttons and dial, which are on the dialling unit of table-mounted models appear on the front of the teleprinter above the keyboard. Signalling lamps have been incorporated in two of the buttons.

The spare button, to the left of the DIAL button, is provided for possible future developments.

The basic telex installation

How it operates

Each teleprinter has a telex number and an 'answerback' code.

Calls are made by pressing the DIAL button and dialling the number. A green lamp behind the button glows while the installation is in use.

At the called installation, the teleprinter switches on automatically and transmits its 'answerback' code to confirm that the correct number has been connected.

The caller presses the HERE IS key to indicate who is calling, then types the message.

During a call, either operator can attract the other's attention by pressing the BELL key, which sounds an alarm and lights a red lamp behind the RESET button. The audible alarm is cut off and the lamp goes out when the RESET button is pressed.

At the end of a call it is usual to confirm the connexion by exchanging 'answerback' codes. The caller presses in turn the HERE IS and WHO ARE YOU keys.

Either operator can end the call by pressing the CLEAR button.

Summary of facilities

All the typing operations of the teleprinter are power-assisted, and a good typist can easily achieve 35 to 40 words a minute.

Everything that is typed during a call appears simultaneously on both machines.

With a suitable ribbon, the teleprinter can print in two colours; one for incoming and one for outgoing messages.

Single-ply paper, or multi-ply with up to five undercopies can be used.

The paper is 8½" (216 mm) wide and up to 69 characters or spaces form each line. A warning lamp above the keyboard glows when approximately 55 characters or spaces have been typed on a line.

The caller can set the line feed of his own machine for single, intermediate or double spacing.

A buzzer can be switched on, when required, to signal incoming calls. An extension alarm can also be provided.

Messages can be received even when the office is closed provided there is an adequate amount of paper in the teleprinter. An incoming call automatically starts the machine, and it is switched off when the distant operator presses the CLEAR button.

The teleprinter can be switched to local use for practice or message copying. If an incoming call is received, the audible alarm and red light behind the RESET button warn the operator. After a short interval the teleprinter is automatically connected to the line so that the call can be received. The alarms can be stopped by pressing the RESET button.

The console model economises on floor space. Allowing room for the operator's chair and maintenance requirements the compact installation occupies only 9 sq. ft. (0.84 sq. m.)



The installation with automatic transmission facilities.

Message preparation

Punched paper tape is prepared with the teleprinter in LOCAL use and the PERF ON key depressed. The tape is punched as the message is typed, and accuracy is checked from the printed page copy.

Errors on the tape can be corrected.

To ensure that an edited message is correct, a punched tape can be 'played-back' on the teleprinter.

The tape bearing the message is loaded into the automatic transmitter on the teleprinter ready for sending.

How it operates

This installation is operated in the same way as the basic installation, described earlier, with the following exceptions.

When required during a call, the automatic transmitter, is switched on to send the message at the maximum speed of the machine. The keyboard cannot be used while the automatic transmitter is in use. When the message ends, the transmitter stops and this is signalled by the alarm and red lamp.

The BELL key should not be used to attract the other operator's attention while the automatic transmitter is in use.

The WHO ARE YOU key can be used at any time during a call, but should not be used when transmitting automatically.

The HERE IS key can be used at any time during a call, but should not be operated when transmitting automatically.

A character can be printed and punched continuously with the RUN OUT key. This assists in identifying the beginning and end of a tape with blocks of repeated perforations. The key can also be used to extend the tape so that the message is clear of the teleprinter before the tape is detached.

Summary of facilities

In addition to all the facilities provided by the basic installation, there are the following advantages.

Messages can be sent at the maximum speed of the machine which is about 70 words (400 characters or spaces) a minute.

Automatic transmission shortens the duration of a call.

When a message is sent, the transmission can be checked on the page copy produced at the same time.

An automatic transmission can be interrupted by the distant installation. If a key is pressed on that machine, an alarm and red light warn that the transmitter should be stopped to find out why the call has been interrupted.

Messages on paper tape can be used many times to transmit to different destinations. A heavy duty tape is available for this purpose. Additional page copies or punched tapes can be prepared from the original.

On an incoming call, a message can be produced on paper tape as well as on page copy, if required. This is useful when the message has to be relayed.

Incoming calls during tape preparation, are indicated by an alarm and a red light. The tape punch is disengaged and after a short interval the teleprinter is automatically connected to the line. The alarms can be disconnected by operating the RESET button.

Alarm signals are given and the transmitter is stopped at the end of a tape transmission or if a call is disconnected.

General information

The following facts apply equally to both installations

The console must be sited so as to give a clearance of 7" (178 mm) on the left hand side and 12" (305 mm) on the right for maintenance purposes. The machine can be sited with less clearance provided it can be drawn clear for the whole of its depth.

The teleprinter has a sound-reducing cover with a window through which the message can be read. The cover is hinged so that the paper can be replaced or the ink-ribbon changed without difficulty.

The console houses the power and auxiliary apparatus, and the installation works from a 3-pin switched socket outlet, of at least 5-amp rating, provided by the customer.

All leads and connexions are contained within the console, and the only visible cables are the mains supply and telex line which are brought out at the foot of the pedestal.

The console is finished in light french grey and elephant grey to match the teleprinter, and the footrest is covered with a black rubber mat.

The console with basic telex installation weighs 190 lb (86 kg), and 195 lb (88 kg) when the teleprinter has automatic transmission facilities.

Dimensions

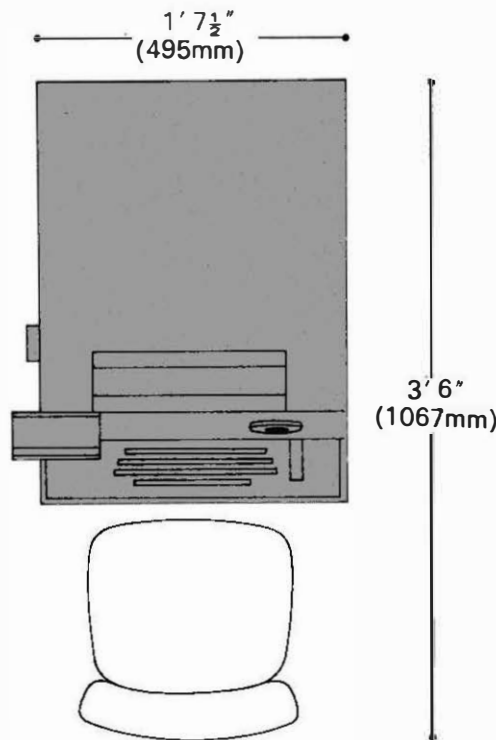
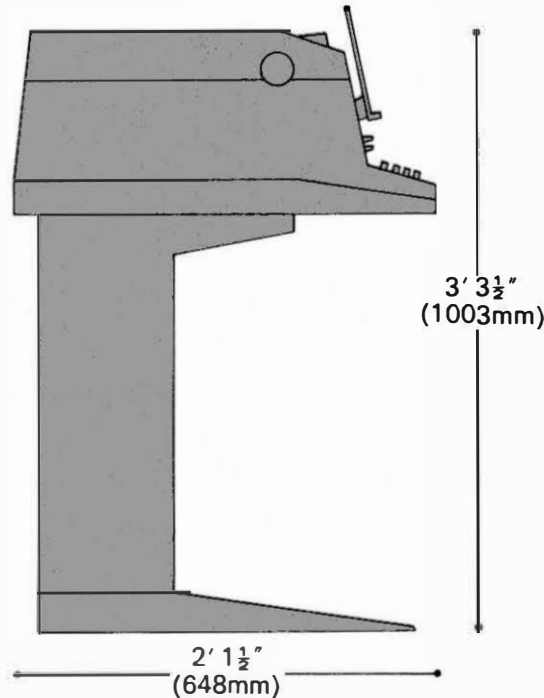

Please note

We do our best to supply our customers with the apparatus they ask for but we may have to provide apparatus which does not accord exactly with the descriptions and illustrations in this leaflet.

Rental and connexion charges are quoted in DLG 1 the preface sheet for section G descriptive leaflets.

Your Telephone Sales Office will gladly supply any further information
The address and telephone number are shown in the preface of your telephone directory.