

Crown Copyright Reserved

Post Office Engineering Department

**TECHNICAL PAMPHLETS
FOR WORKMEN**

Subject :
Wiring of Subscribers' Premises

ENGINEER-IN-CHIEF'S OFFICE.

May 1934

(Reprinted, January. 1935)

LONDON

PRINTED AND PUBLISHED BY HIS MAJESTY'S STATIONERY OFFICE

To be purchased directly from H.M. STATIONERY OFFICE at the following addresses :

Adastral House, Kingsway, London, W.C.2; 120, George Street, Edinburgh 2

York Street, Manchester 1; St. Andrew's Crescent, Cardiff;

80 Chichester Street, Belfast;

or through any Bookseller

1937

Price 6d. Net

LIST OF Technical Pamphlets for Workmen.

GROUP A.

1. Magnetism and Electricity.
2. Primary Batteries.
3. Technical Terms.
4. Test Boards.
5. Protective Fittings.
6. Measuring and Testing Instruments.
7. Sensitivity of Apparatus.
8. Standard List of Terms and Definitions used in Telegraphy and Telephony. (*Not on Sale*)
9. Standard Graphical Symbols for Telegraphy, Telephony and Radio Communication. (*not on sale*)

GROUP B.

1. Elementary Principles of Telegraphy and Systems up to Morse Duplex.
2. Telegraph Concentrators.
3. Wheatstone System. Morse Keyboard Perforators.
4. Quadruplex, Quadruplex Repeated Circuits and Telegraph Repeaters, Simplex and Duplex.
5. Hughes Type-printing Telegraph.
6. Baudot Multiplex Type-printing System.
7. Western Electric Duplex Multiplex. Murray Duplex Multiplex. Siemens and Halske Automatic Type-printing System.
8. Fire Alarm Systems.

GROUP C.

1. Wireless Transmission and Reception.
2. Interference with Reception of Broadcasting.

GROUP D.

1. Elementary Principles of Telephony.
2. Telephone Transmission. "Loading." Telephone Repeaters and Thermionic Valves.
3. Principles of Telephone Exchange Signalling.
4. Magneto Exchanges - Non-Multiple Type.
5. Magneto Exchanges-Multiple Type.
6. C.B.S. No. 1 Exchanges-Non-Multiple Type.
7. C.B.S. Exchanges-Multiple Type.
8. C.B. Exchanges-No. 9 Type.
9. C.B. Exchanges-No. 10 Type.
10. C.B. Exchanges-No. 12 Type.
11. C.B. Exchanges-22 Volts.
12. C.B. Exchanges-40 Volts.
13. Trunk Telephone Exchanges.
14. Maintenance of Manual Telephone Exchanges.
15. Telephone Testing Equipment.
16. Routine Testing for Manual Telephone Exchanges.
17. Internal Cabling and Wiring.

[Continued on page iii of Cover.]

**WIRING OF
SUBSCRIBERS'
PREMISES
(F8).**

*The following pamphlets in this series
are of kindred interest:*

- F.1, 2 & 3 Subscribers' Apparatus
F.4, 5 & 6. Private Branch Exchanges
F.7. House Telephones

*The Post Office Technical Instruction XVIII,
"Wiring of Buildings" is also of interest*

CORRECTION SLIP TABLE

The month and year of issue is printed at the end of each amendment in the Correction Slips, and the number of the slip in which any particular amendment is issued can, therefore, be traced from the date. In the case of short corrections made in manuscript, the date of issue of the slip should be noted against the correction.

The Summary portions of the Correction Slips should be completed and affixed below in numerical order.

CORRECTION SLIP TABLE - (contd.)

The month and year of issue is printed at the end of each amendment in the Correction Slips, and the number of the slip in which any particular amendment is issued can, therefore, be traced from the date. In the case of short corrections made in manuscript, the date of issue of the slip should be noted against the correction.

The Summary portions of the Correction Slips should be completed and affixed below in numerical order.

Wiring of Subscriber's Premises (F8)



TABLE OF CONTENTS.

	PAGE
DESIGN OF INSTALLATION	7
WORKMANSHIP	12
WIRE AND CABLES	14
TERMINAL BLOCKS, DISTRIBUTION CASES, PROTECTORS AND MAIN FRAMES	18
FIXING APPARATUS	22
ROUTING, FIXING AND PROTECTION OF WIRING ...	25
EARTH CONNEXIONS AND POWER LEADS	28

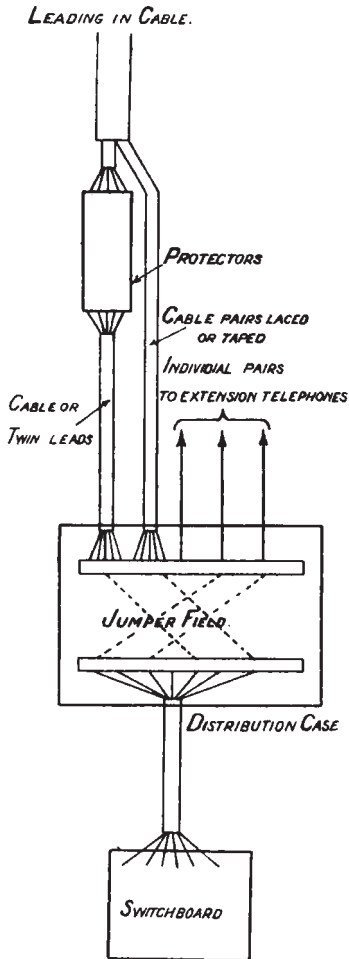

Fig. 1.

Private Branch Exchange with Internal Extensions wired individually and several External Circ. connected, some requiring protection.

WIRING OF SUBSCRIBER'S PREMISES DESIGN OF INSTALLATION.

The wiring of subscribers' premises comes more directly under the observation of the individual user or member of the public than any other part of the plant, and, therefore, calls for a high standard of workmanship.

Before work on any installation is commenced a survey should be made to determine the best method of wiring the apparatus. If the installation is a simple one, consisting of a single instrument or a main instrument and one extension, the fitter will probably be called upon to do this survey himself, but if the installation includes a switchboard the survey will usually be made by a fitting foreman or inspector.

The larger installations fall broadly into the following three classes :-

Class 1.-Small private branch exchanges with the extensions wired directly from the switchboard or from a distribution case or protector fitted therewith.

Class 2 - Large private branch exchanges with cables from a main frame or distribution case to subsidiary cases.

Class 3.- Complex cases of large buildings containing a number of various types and sizes of installation rented by different subscribers.

Class 1.- A typical lay-out for wiring such installations is illustrated in Figure 1.

In wiring small switchboards, if the switchboard terminals are suitably arranged for connecting and disconnecting to locate faults, and individual pairs of wires can be run for every circuit, a distribution case is not required.

The lay-out in Figure 1 shows the external circuits led in on one cable, and divided into two groups - (a) Circuits requiring protection led through protectors, (b) Circuits not requiring protection led direct to the distribution case.

This lay-out must be suitably modified to suit the requirements of the particular installation. If no circuits require protection, protectors are omitted. If the majority of the external circuits led in on one cable require protection, it is generally advisable to lead all the circuits in the cable through a protector fitting.

If the majority of the circuits connected to an exchange require protection, Protectors HC and F40/40, 40/80 or 80/80, which include jumper field, may be fitted in place of a distribution case and separate protectors.

Class 2.- An example of a large private branch exchange with a main frame or distribution case and subsidiary distribution cases is shown in Fig. 2.

Class 3. - In large multiple office buildings where there are a considerable number of subscribers on each floor, one or more distribution cases is fitted on each floor, and cables are run from these to the main exchange cable system in the street. The size of the distribution case and the number of cable pairs connected between it and the main exchange depend on the estimated development on each floor. Fig. 3 shows a typical lay-out for a large building, together with the estimated development figures.

It will be seen that, in addition to the distribution cases on the floors, there is an auxiliary distribution case which is used in the following way:-

The cables from the various distribution cases, including the auxiliary case and the exchange cable from the street, are brought together at the joint J. A proportion of the pairs from each case is there jointed to the exchange cable. The remaining pairs of the exchange cable and of the cables from the distribution cases are connected to the auxiliary distribution case.

If, at any time, the estimated development on a floor is exceeded a further number of exchange circuits to that floor can be readily provided via the auxiliary distribution case. This distribution case is also the means of getting circuits from one floor to another.

The following points should be borne in mind when selecting a room or rooms for use as a large private branch exchange, and, in so far as they are applicable, for a small private branch exchange:-

Size and shape of room to allow of access to all apparatus.

Most economical position in building as regards length of cables required.

Possible extension of equipment.

Lighting, by day and night, both of the face of the switchboard for operating and of the apparatus for maintenance.

Heating and ventilation.

Cloak room and retiring room for operators.

Storeroom for instrument and battery parts if stock is kept.

Accommodation for batteries

LARGE P. B.X. WITH MAIN FRAME (OR DISTRIBUTION CASE) & SUBSIDIARY DISTRIBUTION CASES.

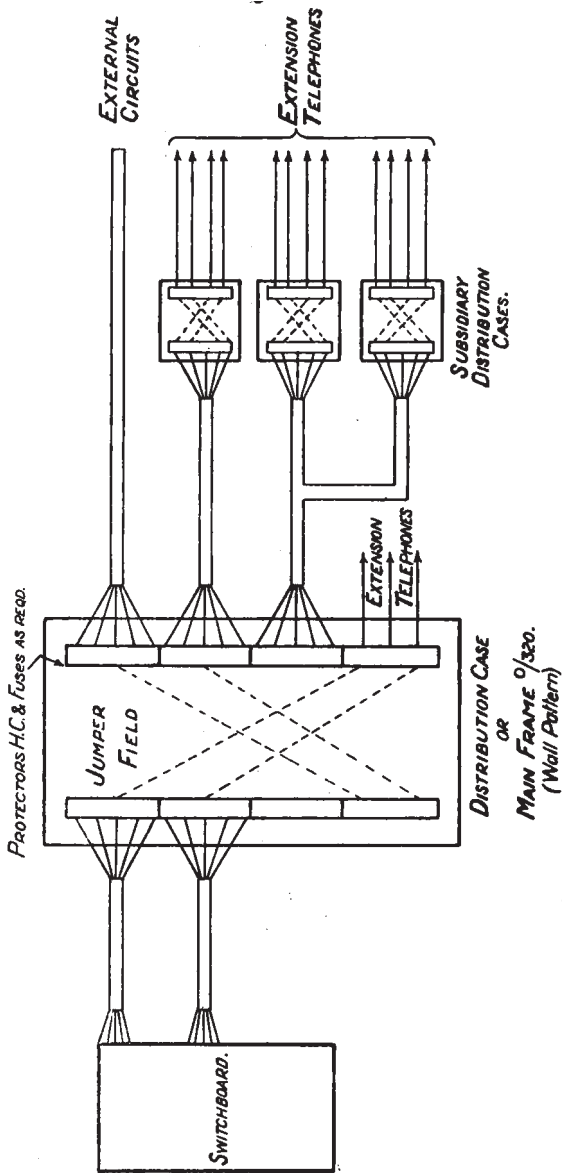

Fig. 2.

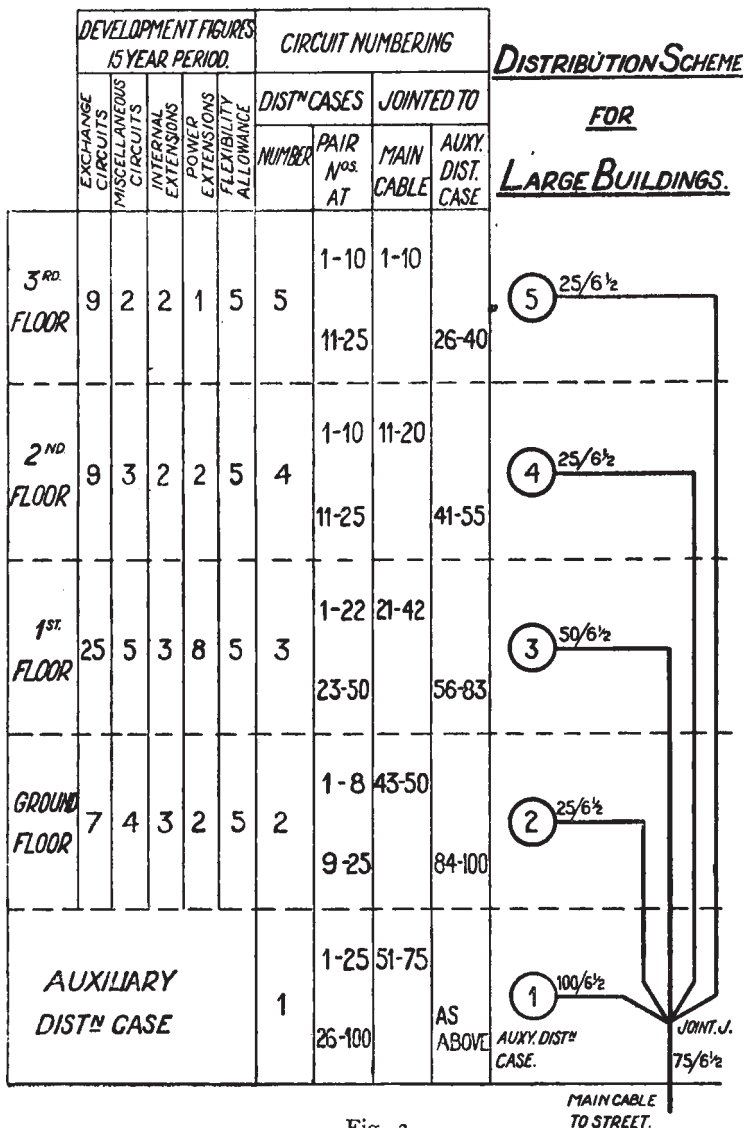

Fig. 3.

Fig. 4 shows the floor plan of a large private branch exchange in which these various factors have been taken into consideration.

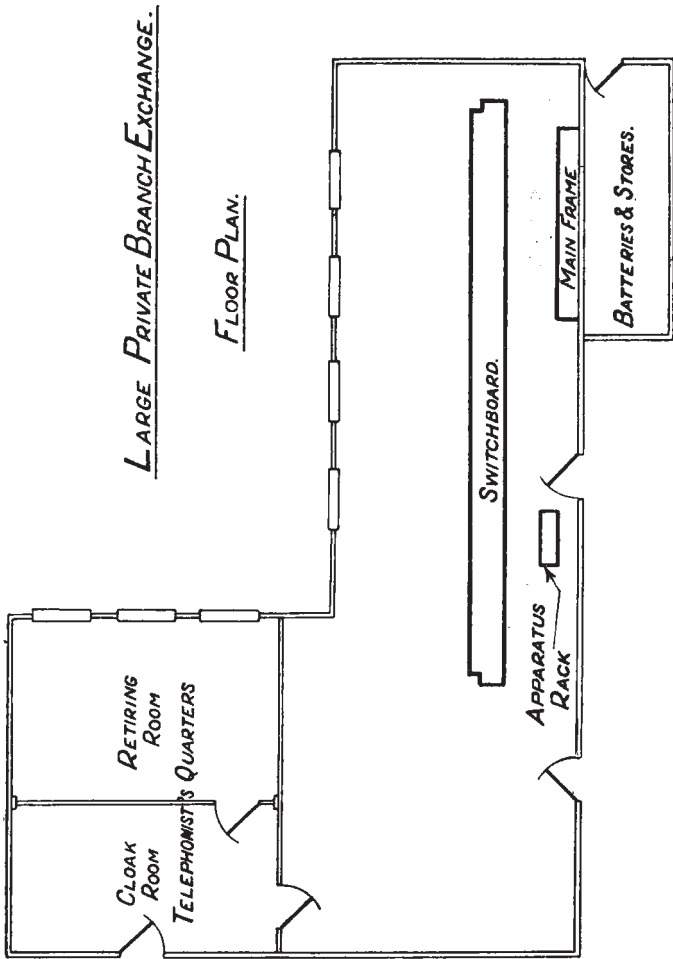

Fig. 4.

In Block wiring and installing P.B. Exchanges, provision is made for development. The development provision may, however, prove to be in-

adequate, and in fitting any piece of plant the possibility of having to extend it, or to fit additional items should not be overlooked.

WORKMANSHIP.

In order that the work of installing apparatus and wiring at subscribers' premises may be carried out in an efficient manner, each workman should carry with him a kit of the necessary tools, which should be maintained in a good condition.

Particular attention should be paid to the state of **edged tools**. They should always be kept sharp and the edges or points protected. Broken and unserviceable tools should be changed immediately. Screwdrivers should be properly shaped so that the heads of screws are not damaged.

A supply of **staples, pins, nails and screws** of various sizes in general use should be carried, the different items being kept in tin boxes or in small bags, and not mixed up indiscriminately in the bottom of the tool bag.

Supplies of **lacing twine, adhesive insulating tape, beeswax and insulating compound No. 5** should also be carried.

Instructions and all other papers should be carried in a wallet, and kept in a clean and tidy manner. Entries thereon should be legibly written. Figures should be particularly clear, and corrections made by crossing out the original figures and not by writing over.

Apparatus carried from store to job *should be wrapped in a waterproof sheet securely tied with cord.*

When the position of any piece of apparatus is being considered, regard should be paid both to the use to which it will be put by the subscriber and to its accessibility for testing and clearing of faults.

Apparatus should not be fitted in a dark, damp, or dusty place, or where it is liable to be damaged by inquisitive people or children.

All instruments should be fitted plumb and level. The right gauge and length of screw, with the correct shaped head, should be used in all cases. Iron screws should be greased before being driven.

Notices and instruction cards should be fitted either in frames or with brass-headed tacks.

A considerable amount of **plugging can sometimes be avoided** by using a backboard when apparatus is to be fitted on a brick or stone wall.

A backboard should also be used whenever any considerable number of items is to be fitted and connected to one another, holes being drilled through the backboard at the various terminals and the wiring run behind the board. *When there is a probability of the wall being damp the wiring should be on the face of the board.*

When making fixings to the surface, or when cutting holes in floors or walls, the greatest care must be exercised to avoid damage to hidden pipes, cables or wires of any kind.

When stapling wire, the work should be done downwards or from right to left, so that the wire can be held taut with the left hand whilst the staple is driven in with the right.

The ends of all cables and wires should be made off neatly and tidily, and no frayed ends of insulation left. The method of making off the various types of wire and cable is detailed later.

The bare ends of wires should not be longer than necessary. When connected to a screw terminal the end should be taken from left to right, so that the action of screwing up the terminal tends to draw the wire in tighter. When the terminal has a hole with a screw grip, the wire should be doubled back on itself before being inserted.

Any piece of **apparatus that has more than one circuit connected should be clearly marked** with the names and numbers of the various circuits or cable pairs. Also, whenever two or more pieces of similar apparatus are fitted on the same installation, they should each be marked with a circuit number or name. Card records should be provided in connection with main frames. Auxiliary units and other special apparatus should be marked to indicate their use and the circuit to which they are connected.

When work is completed it should be thoroughly tested through. If a testing officer is stationed at the main exchange the test should be made with him.

The operation of all instruments, and particularly of switchboards, should be carefully explained to the subscriber when an installation is ready for use. Subscribers should be requested to try the apparatus themselves before the usual expression of satisfaction is asked for.

Before leaving a subscriber's premises all scrap ends of cable wire and covering should be cleared up, and inspection made to see that loose staples, screws, etc., are not left inside any of the apparatus.

WIRES AND CABLES.

Copper conductors are used in all internal wires and cables. Frequently tinned conductors are used as a protection against corrosion, particularly where the conductor is in contact with rubber insulation.

The conductors are separately insulated and stranded together in pairs, triples, or quads, according to requirements. Separately insulated wires stranded together and enclosed in an outer covering

form a cable. If no outer covering is provided the whole is described as a twin, triple, or quad wire.

The types of wires and cables available for described in the following paragraphs:

Wire, copper, tinned, 50 lbs., is a bare copper wire coated with tin to prevent oxidation and to facilitate soldering. It is used as a common for connecting together a number of terminals or soldering tabs.

Wire, copper, soft, stranded, is a bare conductor, and is used for earth connections. The sizes are 3/20, 7/18, 7/16 and 19/16. In these fractions the denominator denotes the gauge of the wire, and not the weight per mile, as is usually the case.

Wire, flameproof, has a tinned copper conductor weighing 121 lbs. per mile. It is insulated with rubber, covered with a layer of flameproofed wool, and has an outer braiding of flameproofed wool or cotton. The wire is supplied in single, twin, triple and quad, and is primarily used for jumpers on frames and distribution cases.

Wire, enamelled and flameproof, is insulated first with a coating of elastic enamel, then a lapping of white wool, and an outer covering of braided wool which is treated to render it flameproof. When the wool is stripped from the wire for a length at the end it requires no binding, as the braiding keeps the ends neat and tidy. In stripping the enamel care should be taken to see that it is completely removed and no flakes left which might cause bad connections. This wire is supplied in similar sizes to Wire, flameproof, and is used for the same purpose.

Wire, switchboard, has a conductor of tinned copper weighing 9¼ lbs. per mile, with an insulation of two layers of silken cord and an outer layer of cotton cord laid on alternately with a right and left-hand twist and impregnated with beeswax. The insulation is removed by the use of pliers, and the ends of the silk and cotton cords cut off neatly and tightened by a twist of the finger and thumb, the beeswax holding them in position. The wire is supplied in single, twin and triple, and is used for the internal connections of instruments and switchboards. The two wires

forming the twin are, generally, one a plain colour and the other the same colour striped with white. The plain wire is used for A line or tip, and the striped wire is used for B line or ring-conductor.

Cable, enamelled and flameproof, has a copper conductor weighing 10 lbs. per mile, which is first covered with elastic enamel and then with two lappings of cotton thread. The whole of the wires in the cable is enclosed in a flameproof braiding. This is the class of wire in general use for the wiring of individual circuits in subscribers' premises. It is supplied in twin, triple and quad sizes, also in 4 and 11 pairs which are chiefly used for house telephones. The colours of the wires in the twin cable are white and blue, the white for the A line and the blue for the B line. The triple has blue, orange, green coloured wires, and the quad an extra brown wire.

In making off this cable the braiding should be removed for the length required, by cutting down with a knife, and the edges neatly trimmed with cutting pliers. The length stripped should be sufficient to leave about an inch of bare wire when the end is completely made off.

The lapped cotton should be unwound to within about an inch or two of the braiding and the longitudinal layer removed to that point. The lapped cotton should then be finished off with two half-hitches and the ends neatly cut off. These half-hitches should be made with the cotton fiat on the wire.

All traces of the enamel should be carefully removed to within $\frac{1}{4}$ in. of the knot.

Before cutting back the braiding or unwinding the lapped cotton the cable or wire should be rubbed with beeswax to hold the threads together.

When the wires are connected care should be taken to see that the cotton covering of the cable or wire does not come into contact with the terminals or tabs.

Cable, enamelled and cotton covered, has 10lb. conductors insulated first with elastic enamel and then with two layers of cotton lapped in reverse directions and impregnated with wax; the whole is enclosed in a lead sheath. It is supplied in the same sizes as Cable E. and F.P., also in 6, 7 and 9-pair sizes. It is used for the same purposes in situations where the flameproof cable would be liable to damage from moisture or other causes.

Cable, paper Covered, twin, has copper conductors weighing $6\frac{1}{2}$ lbs., 10 lbs., or 20 lbs. per mile. It is the type of cable in most general use

and is made up in a large variety of sizes, some of which have a portion of the conductors of one weight per mile and the remainder of another. Such cables are called composite cables. The insulation of this type of cable is mainly dry air, the paper serving primarily to keep the conductors apart. This type of cable is particularly suitable for use for telephone circuits on account of its low capacity. It is essential that all moisture should be carefully excluded as the insulation resistance decreases very rapidly if the paper and air become damp. Each conductor is covered with two layers of paper, the first of which is longitudinal and the second spiral. The conductors are twisted together in pairs and spiralled with cotton thread. The papers and threads are of various colours and combinations of colours for identification purposes. The cable is protected by a lead sheath. This type of cable is never connected direct to apparatus but is terminated with a length of enamel silk and wool core cable or in a terminal block.

Cable, enamel silk and wool core, has conductors of copper weighing 10 lbs. or 20 lbs. per mile, twisted in pairs. Each conductor is completely and uniformly covered with a triple coating of flexible insulating enamel capable of withstanding certain chemical, mechanical and electrical tests. Each enamelled conductor is then tightly covered with two lappings of undyed silk laid on in opposite directions and then with one close lapping of wool. Two conductors insulated as described are lapped with coloured wool and twisted together to form a pair. The pairs are then stranded into a compact and symmetrical cable which is thoroughly impregnated with a compound of beeswax and petroleum jelly and covered with a lead sheath.

Cable, switchboard, has conductors of tinned copper weighing generally $9\frac{1}{4}$ lbs. per mile, but heavier conductors are used for special purposes. The chief use of this cable in the wiring of buildings is for connection between the switchboard and the distribution case or main frame. It is also used for internal connections of switchboards, the wiring of special apparatus and, when conditions are suitable, for connection between the main and subsidiary distribution cases. Each wire is insulated with layers of silk and cotton, or silk and wool, lapped in opposite directions, and the wires are in single, pairs, or triples according to the circuit for which the cable is required. The whole of the conductors, after being stranded, are wrapped with successive layers of (1) cotton cords, (2) paper tape, (3) lead foil, (4) waxed paper, (5) cotton cord, and, finally, are

covered with a braiding of flameproof material and painted with fire-resisting paint.

The colour scheme of these cables is given in the following table.

Colour Scheme for Switchboard Cables.

Col. 1.	Col. 2	Col. 3.	Col. 4
1. Blue	White	22. Red, blue	Red
2. Orange	„	23. Red, orange	„
3. Green	„	24. Red, green	„
4. Brown	„	25. Red, brown	„
5. Slate	„	26. Red, slate	„
6. Blue, white	„	27. Red, blue, white	„
7. Blue, orange	„	28. Red, blue, orange	„
8. Blue, green	„	29. Red, blue, green	„
9. Blue, brown	„	30. Red, blue, brown	„
10. Blue, slate	„	31. Red, blue, slate	„
11. Orange, white	„	32. Red, orange, white	„
12. Orange, green	„	33. Red, orange, green	„
13. Orange, brown	„	34. Red, orange, brown	„
14. Orange, slate	„	35. Red, orange, slate	„
15. Green, white	„	36. Red, green, white	„
16. Green, brown	„	37. Red, green, brown	„
17. Green, slate	„	38. Red, green, slate	„
18. Brown, white	„	39. Red, brown, white	„
19. Brown, slate	„	40. Red, brown, slate	„
20. Slate, white	„	41. Red, slate, white	„
21. Red	„	42. Red, white	„

21-wire cables are made by Columns 1 or 3.

42-wire cables are made by Columns 1 and 2 twinned.

63-wire cables are made by Columns 1 and 2 twinned and Column 3.

84-wire cables are made by Columns 1 and 2 twinned with Columns 3 and 4 twinned.

The general way in which the wires of the various colours are connected is as follows. The white wire is used for the tip or A line, those coloured as shown in the first column for the ring or B line, and those coloured as in the third column for the test or sleeve wire, while the red wire is used for the lamp.

When it is required to terminate this cable, the various outer coverings are stripped back to the point required and the ends are then dipped in hot beeswax and the wax allowed to soak well up under the outer

covering. When waxing the cable, the identification of the various colours after waxing is greatly facilitated if about an inch at the end is left unwaxed. The cable is then clamped to a lacing board and the wires laid out in order, either through holes or round pins, and laced together with twine.



Fig. 5.

The knots should always be made so that the ends come out from under the loop (see Fig. 5) and the loops should be evenly spaced and pulled tight.

TERMINAL BLOCKS, DISTRIBUTION CASES, PROTECTORS, AND MAIN FRAMES.

Wires and Cables are terminated, according to circumstances, on terminal blocks, protectors, distribution cases, or main frames.

Terminal blocks Nos. 1, 2, 3, and 6, which have 2, 4, 8, and 20 terminals respectively, are used to connect small underground cables to internal wiring where a distribution case is not provided. These blocks are designed with a recess into which the lead-covered cable is led and jointed to the internal wire. The recess is then filled with compound No. 5, which serves to seal the paper-covered cable and to insulate the joints.

Distribution cases (see Fig. 7 of P.W. - D.18) are fitted at points at which it is desired to connect, without protection, 5 or more pairs of external cable to internal wiring, and whenever it is desired to provide a variable connection between one cable and another, or individual wires or leads. They also serve as testing and localising points, especially when fitted in connection with a private branch exchange.

The standard sizes of distribution cases are 20, 40, 80, 160 and 240-wire. The 20-wire case is provided with 40 terminals to enable 10 circuits to be led in and 10 circuits led out, with cross connections between the terminals. The terminals are of the combined soldering tab and screw connection type. The cross connection or jumper is connected to the screw terminal and the cable or lead connected to the soldering tab. Jumpers should be run for every circuit, always through the rings provided. They should never be connected straight across, even if it is desired to connect one terminal to another which is directly opposite. When a circuit is made spare the jumper should be recovered, but it is advisable to leave connected the wire from the case to the office.

CASE, DISTRIBUTION, 80 WIRE

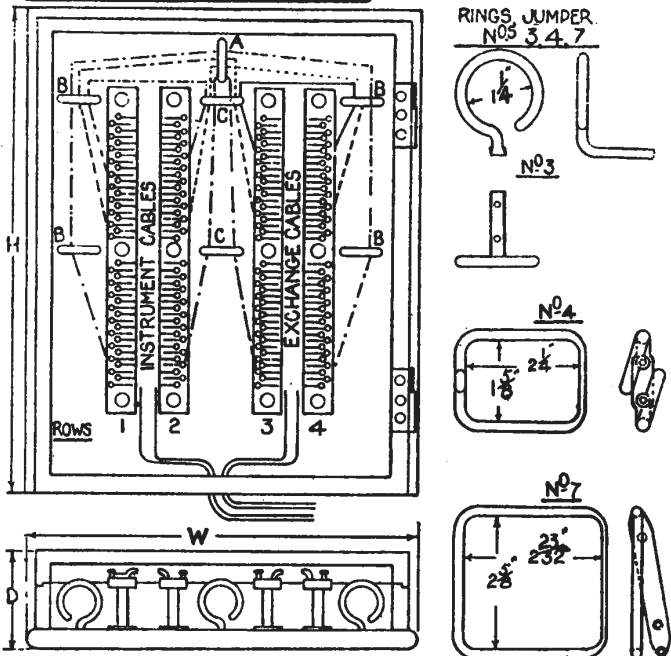

CASE DISTRIBUTION NO. OF WIRE (AS UNDER)	SIZE			STRIP CONNECTION			RINGS, JUMPER						LABELS		
	W.	H.	D.	NO. OF ROWS	QTY.	TITLE NO.	QTY.	TITLE NO.	QTY.	TITLE NO.	QTY.	TITLE NO.	QTY.	TITLE NO.	
10 WIRE (MARK 234)	5	13/4	3/8	1	1	N02	-	-	-	-	-	-	-	1	N22A
20 WIRE	10 7/8	17 1/2	3/8	2	2	N02	1	N03	-	-	-	-	-	20	N27
20 WIRE (MARK 234)	10 1/4	13 1/8	5/8	2	2	N02	1	N03	-	-	-	-	-	1	N22B
40 WIRE	10 7/8	17	3/4	2	4	N02	2	N03	-	-	-	-	-	40	N27
40 WIRE (MARK 234)	15 1/8	13 1/8	3/8	4	4	N02	4	N03	2	N03	1	N03	1	22C	
80 WIRE	12 1/2	27	5/4	2	2	N03	-	-	-	-	4	N03	80	N27	
80 WIRE (MARK 234)	15 1/2	19 3/4	3/8	4	4	N04	4	N03	4	N03	2	N03	1	22D	
160 WIRE *	15 5/8	33 1/8	5/8	6	4	N03	1	N07	8	N03	4	N04	160	N21	
160 WIRE (MARK 234)	16 1/8	33 1/8	5/8	4	4	N03	2	N03	8	N03	4	N03	1	22E	
240 WIRE *	21 5/8	33 1/8	5/8	6	6	N03	2	N07	8	N03	8	N04	240	N21	
480 WIRE *	33 1/8	33 1/8	5/8	6	12	N03	5	N07	8	N03	20	N04	480	N21	

* IN THESE ITEMS THE DOORS ARE NOT HINGED BUT LIFT OFF

FIG. 6.

The object of providing a jumper field and the use of jumpers is to provide a means of connecting any pair of a cable to any other pair on the case, and to vary such connections at will without at any time altering the permanent connections of the cable.

Protectors are fitted at the point of connection between the internal and external wiring whenever the latter is connected to open wires. Where these open wires cross power circuits or are run in close proximity thereto, heat coils and fuses are also fitted. The various types of protectors, their characteristics and general uses are as follows :

Types of Protectors and their Uses.

Type.-D.

Characteristics. - One pair of protectors, without heat coils or fuses, mounted on a porcelain base with cover.

General Use. - For protecting individual circuits from lightning only. (This type of Protector has been superseded by Protector HC and F 2/2

Type. - HC and F 2/2

Characteristics. - One pair of protectors, heat coils and fuses on a porcelain base with cover.

General Use. - For protecting individual circuits from lightning and power.

Type. - HC and F 0/10

Characteristics. - Iron frame with cover capable of mounting 5 protectors HC and F201 each of which protects one pair of wires or, alternatively, 5 blocks terminal No. 5 each of which terminates 2 pairs of wires.

General Use. - Fitted (sometimes in conjunction with a distribution case) at a P.B.X., and can be used for circuits either requiring protection or not.

Type. - HC and F 0/14 and HC and F 0/20

Characteristics. - Similar to 0/10 but accommodating 7 and 10 protectors or terminal blocks respectively.

General Use. - Fitted (sometimes in conjunction with a distribution case) at a P.B.X. and can be used for circuits either requiring protection or not.

Type. - 40 B.

Characteristics. - 20 pairs of protectors and heat coils on a central iron plate 11 inches long.

General Use. - On main frames.

Type. - HC-and Test

Characteristics. - Similar to 40 B but with an extra spring to permit insertion of test clip without removing heat coil.

General Use. - On main frames.

Type. - HC and F 40/40

Characteristics. - Iron base with cover fitted with a strip of 20 pairs of protectors and heat coils, and a strip of 20 pairs of fuses with cross connection facilities between them.

General Use. - Fitted on installations without main frames where protection is required on more than 10 circuits. A distribution case is not necessary if all the circuits on a P.B.X. are connected via one of these protectors.

Type.-HC and F 40/80 and HC and F 80/80

Characteristics.-Similar to 40/40 but accommodating more circuits.

General Use.-Fitted on installations without main frames where protection is required on more than 10 circuits. A distribution case is not necessary if all the circuits on a P.B.X. are connected via one of these protectors.

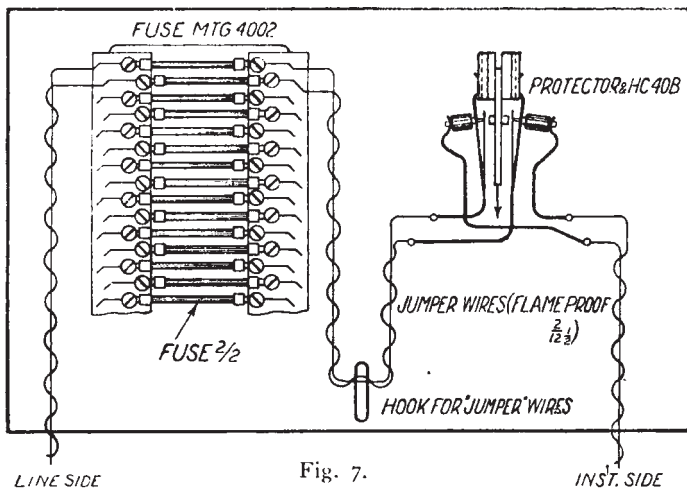

Fig. 7.
DIAGRAM OF WIRING PROTECTORS H.C. & F. $\frac{40}{40}$ & $\frac{80}{80}$.

Protectors should not be fitted in positions where they are likely to be affected by damp or corroded by gas fumes, or where they would be subject to considerable vibration which would tend to displace the carbons, heat coils, or fuses. Care should be taken to put the mica separator between the carbons with the open side downwards and to fit the carbon containing the fusible metal in contact with the earth plate.

Protectors and terminal blocks should be fitted in positions conveniently accessible for use as testing points. They should not be fitted in positions where they would be liable to damage from window blinds or curtains.

Protectors HC and F 20/40, 40/40 and 40/80, which are illustrated in Figure 7, are provided with strips of fuses to which the line wires are connected, and strips of protectors and heat coils to which the internal wiring is connected, with a cross connection field between the two strips.

Installations requiring more accommodation than that provided by the largest size of distribution case may be provided with **Frames, Main Distribution, 0/240**. This is a wall fitting type and consists of two verticals, each capable on the front of accommodating six strips, which may be all fuse mountings, or all protectors and heat coils with fanning strips, or all connection strips or a mixed combination of any of the three.

The apparatus strips are not supplied with the frame unless specially asked for, but all the fitting details for these items are supplied fixed in position, with the exception of the metal screws for securing the connection strips to the fixing clips and the wood screws for securing the fanning strips to their clips which are supplied tied to the clips on which they are to be used. The full equipment of jumper rings and earth wire thimbles is supplied fitted in position on the frame.

The frame is suitable for extending in either direction and four bolts and nuts required for this purpose are supplied fitted in the bolt holes drilled in the bent ends on the right of the four main long horizontal bars (see P.W. - D.18 for fuller details).

FIXING APPARATUS.

Whenever possible a wood-lined wall or partition should be selected for fitting the apparatus, provided the position is otherwise suitable. The screws can then be driven directly into the support.

When a **lath and plaster wall** is used a secure fixing can always be obtained by means of small battens screwed to the inner framework of the wall, the struts of which are usually about seven inches apart. Failing this, screws, lath, 3½" can be used, but when using these screws it is necessary first to pierce the wall with a small bradawl to ensure that a lath will be engaged. Some of the screws, in any case, should enter one of the struts or posts of the framework.

When it is necessary to plug a wall, plugs No. 1 (2" + ¾" square) will be found most generally suitable for fixing apparatus. The plugs are tapered obliquely to ½" The hole cut in the wall should be slightly smaller

than the head of the plug and shaped to hold it securely. Great care should be exercised in driving home the plugs, as damage may easily be caused in the next room when plugging a wall of single brick course.

When plugging a **brick wall** the holes should be cut between the courses wherever possible. This position gives the best possible hold and reduces the probability of a brick being forced out of position.

Considerable skill is required in obtaining fixings to **tiled walls**. The apparatus should first be held up to the wall and the position of the screws marked with a pencil. The glazed front of the tile should then be cut out, where required, by the use of a chisel-ended punch. Great care is necessary in using the hammer until the punch has passed through the tile, when the hole may be completed with a plugging chisel. A better method is to drill a small hole and to use a roll of strip lead instead of a wood plug.

As the **steel in reinforced concrete** is always beneath the surface, it is difficult to plug such walls without meeting some obstruction. If the hole first made fouls the steel, another to the right or left should be attempted until a satisfactory fixing is obtained. It is essential that a sharp chisel should be used.

Battens should be used when it is desired to distribute the weight owing to the weakness of a wall, or when it is not possible to attain a fixing in the exact position required by the screw holes in the apparatus.

Wall telephones are usually self-contained, and magneto instruments include in their construction a space for the primary batteries. Wall instruments, with transmitters oil adjustable arms, should be fitted so that: when the transmitter is in its central position it is at the most suitable height for use by tile average person.

Table telephones are not usually complete in themselves. The central battery type calls for a separate fitting termed a "Bell Set", which contains the induction coil, condenser and bell. The magneto type requires a separate battery box. The fixed end of the flexible cord is connected to a terminal block, connection strip, or rosette, to which the wires from the other apparatus are connected.

When a long cord is provided with an instrument in a room with a carpeted floor that is not cleaned with water, the connection strip will be fitted near the floor level, and the cord may be run under the carpet through a hole poked (not cut) therein near the leg of the table. Where the floor is cleaned by washing, the connecting strip should be fitted high up near

the ceiling and the cord suspended so that, whatever the position in which the instrument is placed, the cord does not touch the floor.

When a cord of normal length is fitted, the strip should be fitted on the same level as the top of the table on which the telephone stands.

Hand generators, press-buttons, bell sets, No. 4, keys, 6-pt. 2-position, and other types of **switches**, when fitted in conjunction with a wall telephone should be at a convenient height for operating by a standing person and, when fitted with a table telephone, should have their handles or buttons about 12 inches above the level of the desk or table unless provided with flexible cords to allow them to stand on the desk.

Leclanché Cells are the standard type of primary battery to be fitted.

Cells No. 2a are used for subscribers' circuits generally and for the supply of power to $\frac{1+3}{4}$ and $\frac{2+4}{6}$ cordless switchboards.

Cells No. 1 are used for speaking circuits on busy magneto switchboards and for the supply of power to C.B. switchboards up to $\frac{5+20}{25}$ double cord.

25

Cells supplied from store are complete with manganese chloride or sal ammoniac for use as the electrolyte, and require only the addition of water. When fitted, sufficient water should be provided to allow for that soaked up by the porous pot.

Cells supplied with chloride of manganese as the electrolyte do not give off fumes, and may therefore be placed in air-tight boxes without corrosion of the terminals and wires. This reduces the evaporation of the electrolyte and facilitates maintenance.

The following steps should be taken when necessary to render the boxes air-tight :

When there are holes in the battery boxes that can be covered with "wood strips 3 in. x 2 in." these should be used.

Where the lids of the battery boxes do not fit well, two layers of adhesive insulating tape should be used as a covering.

When holes are drilled through the box for the accommodation of the wire the size of the holes should be only just sufficient to take the wire. Should an existing hole which is too large be used, it should be plugged with compound.

The boxes should be screwed in position whenever this is practicable in order to prevent removal by subscribers, and the spilling of electrolyte.

Butterfly terminals should always be fitted for the connection of the end zinc.

Trembling bells and **magneto extension bells** fitted indoors should be placed high up to avoid interference, but should not be in positions inaccessible for maintenance purposes.

Bells fitted outdoors will be of waterproof type and should be placed under shelter; subscribers will often provide a small shelter specially for the purpose. The life of the bell is greatly prolonged by such protection.

Cordless switchboards are constructed to stand on a table or substantial bracket, and do not require fixing.

Wall pattern switchboards require secure fixing and, when walls are plugged, special large plugs should be made of hard wood, a good fit for the holes, and well driven home. If the wall is thin, or the fixing poor, the weight may be distributed by the use of battens. When the operating telephone is a separate instrument it should be fitted on the left of the switchboard.

Floor pattern switchboards should be secured to the floor.

ROUTING FIXING AND PROTECTION OF WIRING.

The **choice of routes** for the wires and cables in a new or large building will often depend on the wishes of the architect or owner. The route selected should be one that gives reasonable facilities for the extension of the plant and which is easily accessible for the work of running the cables.

It should be the most direct route possible, having regard to these conditions, and not be one in which the cable would be liable to damage. The inaccessibility of lift wells or other places not available for working in at all times will often render such places unsuitable for cable routes.

In the case of new buildings the runs should be agreed with the architect during the construction of the building. It is sometimes an advantage to run the distribution cables whilst the building work is in progress. The co-operation of the Clerk of the Works on the site should be obtained whenever possible as many difficulties can be overcome with his assistance.

Wires and cables should be run in vertical and horizontal lines and always turned at right angles.

The route selected should be one that avoids the risk of damage to gas, water or other pipes, or to other electric cables or wires, whether by the driving in of nails, screws, plugs, staples, etc or any other means.

Before the work is commenced, every effort should be made to ascertain the position of any such pipes or cables near the proposed routes.

Amongst the possible causes of damage to wires and cables are :- contact with power wires or cables or with live conduits enclosing them; wet and damp; water from cleaning operations; the use of ladders and steps ; traffic along corridors; interference by children and inquisitive persons; malice. If any of these cannot be avoided in the selection of the route, they should be guarded against by the use of suitable cable or the provision of casing.

All wires, including earth wires, should be run well clear of compo gas pipes, inflammable material, and electric light wiring.

Where lead-covered cables or earth wires cross a lead or compo gas pipe, the leads will be wrapped with adhesive insulating tape for a distance of at least six inches each side of the crossing. A wood bridge should be fitted when it is necessary to cross electric light casing, conduit or wires.

Staples Insulated are used for securing braided cables. A fibre saddle fitted in the crown of this type of Staple protects the covering and the insulation of the cable. Three sizes are used, viz. :- $\frac{1}{2}$ in., $\frac{5}{8}$ in., and $\frac{7}{8}$ in. Generally the $\frac{1}{2}$ in. staple should be used for fixing one-pair cables, and $\frac{5}{8}$ in. and $\frac{7}{8}$ in. staples for 3-wire and 4-wire respectively.

Lead-covered cables up to $\frac{1}{2}$ in. in diameter should be fixed by means of zinc cleats which are issued in the following sizes $\frac{3}{16}$ in., $\frac{1}{4}$ in., $\frac{3}{8}$ in., and $\frac{1}{2}$ in. These sizes indicate the diameter of the cable for which the cleat is suitable. Cables above $\frac{1}{2}$ in. in diameter are usually enclosed in conduit or casing, but where this is not possible or is unnecessary, the cable should be secured by means of cleats made from lead strip and fixed with plumbers' tacks.

Staples and cleats should be spaced at regular intervals, and care should therefore be taken to mark the approximate position for the cleats or staples before the wiring is commenced. The distance between cleats for lead-covered cables should be 12 in. to 15 in., and that between staples for braided cable 15 in. to 18 in.

Cable on external walls. - Lead-covered cables will always be used when a cable has to be fixed to external walls. When the diameter does not exceed $\frac{1}{4}$ in., the cable will be secured by means of lead lugs. One lug at each fixing point will usually hold two one-pair cables, but where more than two are run together, one lug must be used at each fixing point

for each pair of cables. Whenever possible, a larger size cable should be used as an alternative to several one-pair cables.

When a number of wires are to be run in a building which does not call for the use of casing and capping or conduit, they may be supported by wiring rings (officially described as Hooks No. 11). The use of these rings is to be strongly recommended whenever the class of building lends

Fig. 8.

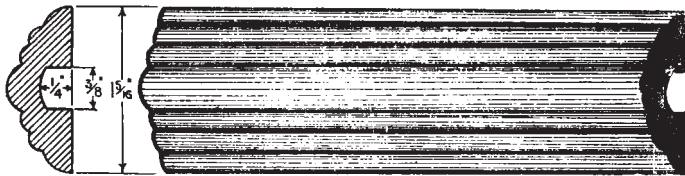
**CAPPING WOOD No. 1.**

Moulded for use on flat surfaces for one pair of wires

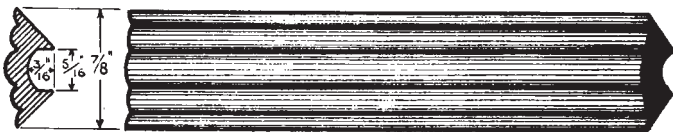
**CAPPING WOOD No. 2.**

Moulded for use in internal angles for one pair of wires.

itself to their use. They effect a large saving of time in the running of wire, and, although the wiring is not enclosed, they make a neat and tidy installation.

Casing or capping should be provided as a mechanical protection wherever cables are run within a foot of lead or compo gas pipe, or of electric light or power wires which are not themselves in casing. It should also be provided when there is any probability of injury to cables or wires from any other cause.

Casing is also provided when a number of wires or cables are run by the same route, or where it is desired for the sake of appearance to keep the wires out of sight.

In order to avoid the necessity for removing long lengths of capping on straight runs, hinges can be fitted to short lengths of capping at intervals, and cables run through by the use of draw-wires.

When it is desired to avoid interference with the decorative effect of a room, and where there is no other method of concealing the wires, they may be covered by a **fancy moulding**. Fig. 8 illustrates two types of such moulding known as Capping, Wood. Nos. 1 and 2, No. 1 being used on flat surfaces and No. 2 in angles. Each is designed to cover one pair of wires.

When the architect or owner of a building insists on the wiring being buried in the walls or floors, **steel conduits** may be used.

Junction boxes must be provided at corners and at branches, and the cables pulled through from one to another of these by draw-wires.

When steel conduit is used the whole system will be made electrically continuous and efficiently connected to earth.

In order to prevent damage by dampness or rough edges of stone or brick, it is desirable to provide a short piece of conduit where wires pass through walls or floors. When wires are run down walls a length of conduit is often useful as a protection up to a few feet above the floor level.

Casing and cover is usually fixed by screws driven through the back or sides. Conduit, when run on the surface, is secured by cleats or clips.

EARTH CONNECTIONS AND POWER LEADS.

Earth connections are provided for two purposes, (1) to protect apparatus, and (2) to conduct current for operating switchboards or other signalling apparatus.

Good earth connections should be obtained in all cases, and the wire should be run by a route that secures it from damage and is as short and straight as possible.

For connections to lightning protectors the wire should be run as straight as possible, and all sharp bends and twists avoided. Helixes should not be made at the points of connection.

It is not so essential to avoid sharp bends and twists in the case of wires used only for power conduction, but, as the resistance of the earth connection is included in the power circuit, it is of the greatest impor-

tance that the connection should have the lowest possible resistance. In order to obtain this result the wire should be run by the shortest route and the connection to the water pipe or earth plate carefully made.

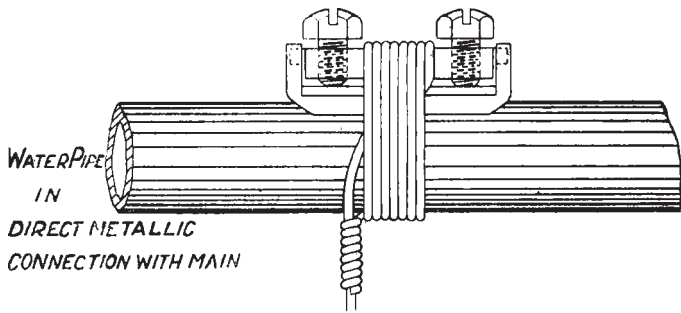

Fig. 9.

Method of connecting earth wires to water services by means of earth Clips No 3

At subscribers' premises the wire used will generally be *Wire, Copper, Soft, 3/20*, but in the case of large installations a heavier conductor may be necessary.

Iron water pipes provide an excellent earth connection, and should be used wherever convenient. *The connection should, in all cases, be made on the street side of the cistern (if one exists).*

When *Wire, Copper, Soft, 3/20* is used as the conductor, contact with the water pipe is obtained by the use of *Clips, Earth No. 1* or *No. 3*. The pipe should be well scraped before connection is made. Figure 9 shows a connection made by the use of an *Earth Clip No. 3*.

When a heavier conductor is required to be connected to a large main a special clamp should be used.

If no suitable water pipes are available an earth plate should be sunk and the connection made thereto.

Main distribution frames, iron cases of protectors, special apparatus racks, and similar items should be connected to earth in addition to the connections to the protective devices themselves. In the case of large multiple office buildings an earth wire should be run to each distribution case and connected there to a number of terminals on the line side of the case. This will provide points for connection of the earth wires for the power circuits of any private branch exchanges served from the case.

N.962 1-11-23.
 GB1247.

**BRANCH EXCHANGES NON-MULTIPLE TYPES.
 EARTH & BATTERY CONNECTIONS.
 WIRING DIAGRAM.**

FIG. 1. EARTH CONNECTION DIRECT.



FIG. 2. EARTH CONNECTION VIA M.D.F. OR DISTRIBUTION CASE.

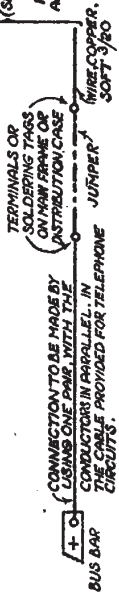

FIG. 3. EARTH CONNECTION TO PROTECTORS.

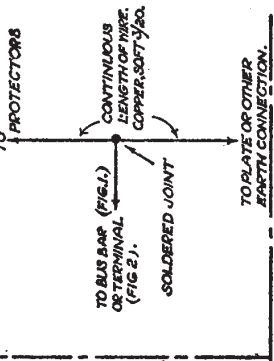

FIG. 4. PRIMARY BATTERY CONNECTIONS.

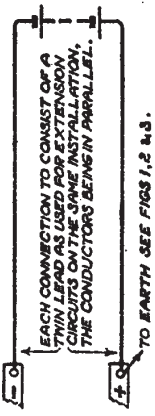
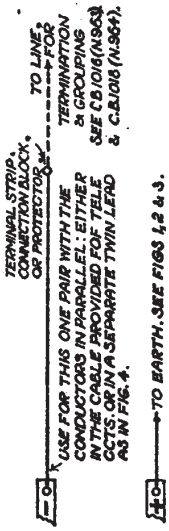

FIG. 5. POWER LEAD CONNECTION.



Power for the operation of private branch exchanges may be supplied by local batteries or by power leads from the main exchange, according to economy or convenience. When power is supplied by local batteries, Leclanché Cells of size suitable for supplying the required current should be fitted.

When current is supplied from the main exchange over a power lead, its resistance, added to that of the earth connection, must be such that, when the maximum number of connections required at the switchboard has been made, sufficient current is conducted to operate all the apparatus in use. This requires that, at the time of maximum load, a certain minimum voltage depending on the type of switchboard, must be maintained at the private branch exchange.

Power ringing is supplied to private branch exchanges in certain circumstances. *Metallic circuits*, and not earth returns, *are always provided for ringing leads*.

The class of wire used for connecting the external circuit to the private branch exchange should be similar to that used for the remainder of the circuits, except in the case shown in Loose Leaf Diagram N. 963, Fig. 4. The same protective devices should be fitted as for other external circuits run by the same route, except that heat coils should be replaced by dummies.

The method of grouping a number of wires to form one power lead, and of connecting one or more private branch, exchanges thereto, is shown in Loose Leaf Diagrams N. 963 and N. 964.

The connections from the P.B.X. bus bars to earth and power lead or battery should be in accordance with Loose Leaf Diagram N. 962.

Printed under the authority of HIS MAJESTY'S STATIONERY OFFICE
By HARRISON AND Sons, LTD., 44-47, St. Martin's Lane, London, W.C.2,
Printers in Ordinary to His Majesty.

LIST OF

Technical Pamphlets for Workmen.

(Continued)

GROUP D - *continued.*

18. Distribution Cases, M.D.F. and I.D.F.
19. Cord Repairs.
20. Superposed Circuits. Transformers. Bridging Coils and Retardation Coils.
21. Call Offices.
22. Units Amplifying (*Not on sale*)

GROUP E.

1. Automatic Telephony: Step by Step Systems.
2. Automatic Telephony:- Coder Call Indicator (C.C.I.) Working.
3. Automatic Telephony: Keysending "B" positions.

GROUP F.

1. Subscribers' Apparatus. Common Battery System.
2. Subscribers' Apparatus. C.B.S. Part I-C.B.S. No. I System.
3. Subscribers' Apparatus, Magneto.
4. Private Branch Exchanges-Common Battery System.
5. Private Branch Exchanges--C.B. Multiple, No. 9.
6. Private Branch Exchanges - Magneto 7. House Telephones.
8. Wiring of Subscribers' Premises.

GROUP G.

1. Maintenance of Secondary Cells.
2. Power Plant for Telegraph and Telephone Purposes.
3. Maintenance of Power Plant for Telegraph and Telephone Purposes.
4. Telegraph Battery Power Distribution Boards.

GROUP H.

1. Open Line Construction, Part I.
2. Open Line Construction, Part II.
3. Open Line Maintenance.
4. Underground Construction, Part I - Conduits.
5. Underground Construction, Part II - Cables.
6. Underground Maintenance.
7. Cable Balancing.
8. Power Circuit Guarding.
9. Electrolytic Action on Cable Sheaths, etc.
10. Constants of Conductors used for Telegraph and Telephone Purposes.

GROUP I.

1. Submarine Cables.

GROUP K.

1. Electric Lighting.
2. Lifts.
3. Heating Systems.
4. Pneumatic Tube Systems.
5. Gas and Petrol Engines.