

FOR OFFICIAL USE.

P.W.—H.7.

Post Office Engineering Department

**TECHNICAL PAMPHLETS
FOR WORKMEN**

Subject :
Cable Balancing.

ENGINEER-IN-CHIEF'S OFFICE,
1919.

LONDON :
PRINTED AND PUBLISHED BY
HIS MAJESTY'S STATIONERY OFFICE.
To be purchased through any Bookseller or directly from
H.M. STATIONERY OFFICE at the following addresses :
IMPERIAL HOUSE, KINGSWAY, LONDON, W.C.2, and
28, ABINGDON STREET, LONDON, S.W.1 ;
37, PETER STREET, MANCHESTER ;
1, ST. ANDREW'S CRESCENT, CARDIFF ;
23, FORTH STREET, EDINBURGH ;
or from EASON & SON, LTD., 40 and 41, LOWER SACKVILLE STREET, DUBLIN.

1921.

Price 6d. Net.

== LIST OF ==

Technical Pamphlets for Workmen

GROUP A.

1. Magnetism and Electricity.
2. Primary Batteries.
3. Technical Terms.
4. Test Boards.
5. Protective Fittings.
6. Measuring and Testing Instruments.
7. Sensitivity of Apparatus.

GROUP B.

1. Elementary Principles of Telegraphy and Systems up to Morse Duplex.
2. Telegraph Concentrators.
3. Wheatstone. Morse Keyboard Perforators.
4. Quadruplex. Telegraph Repeaters, Sx., Dx., and Quad.
5. Hughes Type-printing Telegraph.
6. Baudot Multiplex.
7. Western Electric Multiplex. Murray Multiplex. Other Systems.
8. Fire Alarm Systems.

GROUP C.

1. General Principles of Wireless Transmission and Reception.

GROUP D.

1. Elementary Principles of Telephony.
2. Telephone Transmission. "Loading." Telephone Repeater and Thermionic Valves.
3. Principles of Telephone Exchange Signalling.
4. Magneto Exchanges—Non-Multiple Type.
5. Magneto Exchanges—Multiple Type.
6. C.B.S. Exchanges—Non-Multiple Type.
7. C.B.S. Exchanges—Multiple Type.
8. C.B. Exchanges—No. 9 Type.
9. C.B. Exchanges—No. 10 Type.
10. C.B. Exchanges—No. 12 Type.
11. C.B. Exchanges—22 Volts.
12. C.B. Exchanges—40 Volts.
13. Trunk Telephone Exchanges.
14. Telephone Exchange Maintenance.
15. Telephone Testing Equipment.
16. Routine Testing for Telephone Exchanges.
17. Internal Cabling and Wiring.
18. Distribution Cases, M.D.F. and I.D.F.
19. Cord Repairs.
20. Superposed Circuits, Transformers, etc.
21. Call Offices.

(Continued on page iii of Cover.)

CABLE BALANCING.

(H.7.)

The following publications are of kindred interest.—

PAMPHLETS IN THIS SERIES.

D.2.—Telephone Transmission. “Loading.” Telephone Repeaters and Thermionic Valves.

D.20.—Superposed Circuits, Transformers, etc.

POST OFFICE TECHNICAL INSTRUCTIONS.

T.I.XIX.—Testing and Jointing of Cables required for Superposed Telephone Working. LINES, U.G. C-1000-1099. 11/33

T.I.XX.—Loading of Underground Air Space Paper Core Cables.

I.P.O.E.E. PAPER.

No. 68.—The Loading of Underground Telephone Cables for Phantom Working. By J. G. Hill.

TABLE OF CONTENTS.

	PAGE
Testing and Jointing of Air Space Underground Cables which require to be Loaded and Balanced for Superposed Telephone Working	3
Method of “Balancing” Trunk Cables	7
Method of jointing lengths of cable together in order to eliminate capacity unbalance	11

CABLE BALANCING.

TESTING AND JOINTING OF AIR SPACE UNDERGROUND CABLES WHICH REQUIRE TO BE LOADED AND BALANCED FOR SUPERPOSED TELEPHONE WORKING.

Underground cables which are used for superposing are usually of the Multiple Twin Type. These cables are built up of two-pair cores, each pair consisting of two wires twinned together, and each core consisting of two pairs twinned together. For convenience in explanation the four wires of a two-pair core will be lettered A, B, C, D; A and B being the wires of one pair, and C and D the wires of the other pair.

When a third circuit is superposed upon a two-pair core the arrangement is as shown in Fig. 1.

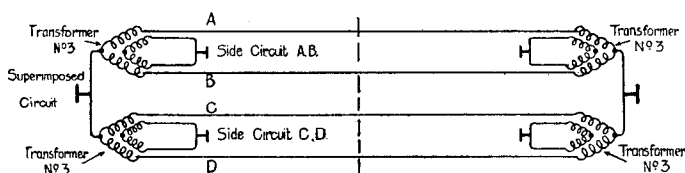

Fig.1

In practice, this superposed circuit is very efficient, but trouble is experienced owing to overhearing between the Superposed circuit and the Side circuits AB and CD, and also to a lesser extent between the Side circuit AB and the Side circuit CD. This overhearing is considerably increased when the circuits are loaded.

A consideration of the Wheatstone Bridge as used for measuring resistances will show the cause of this overhearing, and also explain the method of overcoming the trouble.

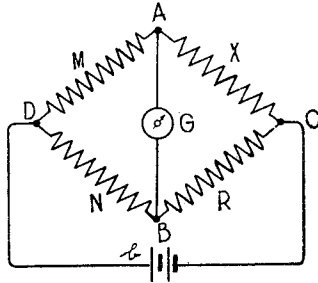

Fig. 2.

Fig. 2 is a diagram of a Wheatstone Bridge in which A, B, C and D are the four corners of the bridge, M and N are the ratio arms, R is the resistance in the fourth arm of the bridge required to "balance" the unknown resistance X. G is the galvanometer, and *b* the battery.

It is well known that if

$$\frac{M}{N} = \frac{X}{R}$$

then this bridge will be balanced, or, in other words, no current will flow through the galvanometer G when the battery is joined to C and D.

Also, of course, it follows that if

$$\frac{M}{N} \text{ is not equal to } \frac{X}{R}$$

then a current will flow through the galvanometer G when the battery is joined to C and D.

If the battery be replaced by a buzzer, and the galvanometer by a Telephone Receiver, then the buzzer current will be heard in the telephone unless

$$\frac{M}{N} = \frac{X}{R}$$

Similarly, if one telephone be joined to C and D, and another telephone to A and B, then speech in the one telephone will be heard in the other unless

$$\frac{M}{N} = \frac{X}{R}$$

In other words, there will be "overhearing" between the two telephones.

Now, a two-pair core of a Multiple Twin Cable is similar to a Wheatstone Bridge; but the arms of the bridge are capacities, instead of resistances.

Fig. 3 shows the four wires A, B, C and D of a two-pair core, in cross section, with the capacities w , x , y and z between the wires. The wires are arranged in this manner in order to show more clearly the similarity to a Wheatstone Bridge.

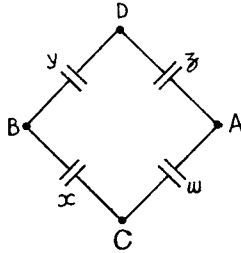

Fig. 3.

Actually, the Bridge made up of the capacities in a two-pair core is not quite so simple as shown in Fig. 3. Each of the wires A, B, C and D has a capacity to the cable sheath or "earth," in addition to the capacities to the other wires in the core.

All the capacities in a two-pair core are shown in Fig. 4, except the capacities between A and B, and between C and D, which need not be considered.

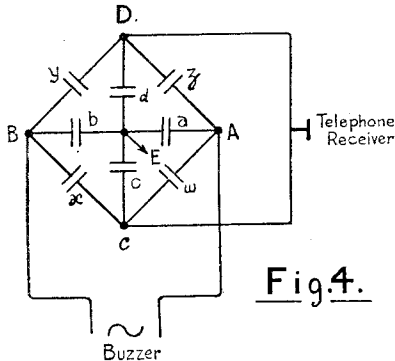

Fig. 4.

In this diagram,

- w = capacity between A and C.
 x = " " " C " " D.
 y = " " " B " " D.

z	=	capacity	between	D	„	A.
a	=	„	„	A	and	cable sheath or earth.
b	=	„	„	B	and	cable sheath or earth.
c	=	„	„	C	„	„
d	=	„	„	D	„	„

A buzzer is shown joined to A and B, and a telephone receiver to C and D.

It can be proved that this bridge will be "balanced" if

$$w = x = y = z$$

$$\text{and } a = b, \text{ and } c = d.$$

In other words, if a buzzer be joined to A and B, then no current from the buzzer will flow through the Telephone Receiver joined to C and D if the above conditions hold.

Similarly, if one telephone be joined to A and B, and another telephone to C and D, then speech on one telephone will not be heard in the other if the above conditions hold. That is, there will be no "overhearing" between the side circuits in this two-pair core.

Fig. 5 shows a two-pair core in cross section with a telephone receiver joined to each of the side circuits AB and CD through Transformer No. 3; and a buzzer joined to the superposed circuit.

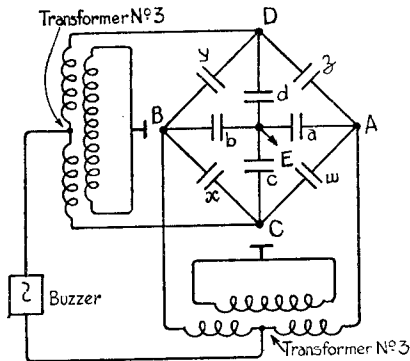

Fig. 5.

It can be proved that if the conditions stated above hold; namely, if,

$$w = x = y = z$$

$$\text{and } a = b; \text{ and } c = d,$$

then no current from the buzzer joined to the superposed circuit will flow through either of the telephone receivers joined to the side circuits AB and CD.

Similarly, speech on the superposed circuit, will not be heard on either of the side circuits, and *vice versa*.

1/28 It can therefore be stated that overhearing in multiple twin cables, between the side circuits, and between the superposed circuit and the side circuits, is due to the capacities between the wires being unequal, and the capacities between each wire and the cable sheath, or "earth," being unequal. In other words, overhearing is due to "capacity unbalance."

Also, the condition for *no* overhearing between the Side circuits, and between the Superposed circuit and the Side circuits is,

$$w = x = y = z$$

$$a = b$$

$$\text{and } c = d,$$

where w , x , y and z are the capacities between the wires, usually termed the wire to wire capacities, and a , b , c and d are the capacities of each of the four wires to earth, usually termed the wire to earth capacities, as shown in Fig. 4.

It should be remembered, however, that in order that there may be no overhearing between any two circuits in a cable, it is necessary, in addition to the above capacities being "balanced," that the conductor resistance, self and mutual inductance, and leakage, of all the wires in the cable should be "balanced" also. It is found in practice that these quantities are sufficiently well balanced by the careful manufacture of the cable, and therefore no special steps need be taken during the jointing of the cable.

METHOD OF "BALANCING" TRUNK CABLES.

The wire to wire capacities in a cable depend principally (since the dielectric is mostly air) upon the distances between the wires. The wire to earth capacities in a cable depend upon the distances between the wires and the sheath of the cable, and also upon the distances between the wires and all the other wires in the cable.

In the manufacture of A.S.P.C. cables it is not possible to insulate and twin the wires of each two-pair core so accurately that the distances between the wires, and between the wires and the sheath, shall all be exactly equal.

The wire to wire capacities w , x , y and z are therefore unequal, as are also the wire to earth capacities a , b , c and d ; and special steps have to be taken to balance these capacities during the jointing of the cable.

The procedure is as follows :—

The wire to wire, and wire to earth capacity unbalances are measured on each length of cable (about 176 yards) after it has been drawn into the ducts.

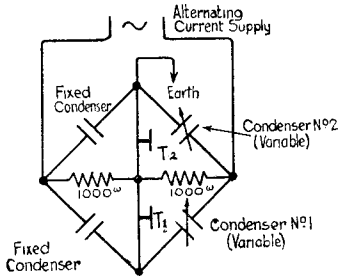

Fig. 6.

For this purpose an alternating current Bridge is used. This Bridge is shown in Fig. 6, and is called the "Double Bridge," because two measurements are made simultaneously.

The Bridge consists of :—

Non-reactive Ratio arms $1000\omega + 1000\omega$

Two Air Condensers continuously variable from 0 to 1200 micro-microfarads, and graduated with centre zero.

Two fixed Air Condensers, 600 micro-microfarads each.

Alternating current is supplied to the Bridge from a Reed Hummer through a special balanced and screened transformer.

Balance is obtained by varying condensers No. 1 and No. 2 alternately until both the telephone receivers T_1 and T_2 are silent simultaneously.

In practice only one telephone receiver is used, and a switch is provided for changing over to the two positions. This receiver must be very sensitive. A wireless headgear receiver of about 2000ω resistance is usually employed.

The Bridge is used to determine the following quantities in each two-pair core :—

$$w-x, z-y, w-z, x-y$$

usually termed the wire to wire unbalances,
and $a-b, c-d$

usually termed the wire to earth unbalances.

In order to determine the above quantities, it is necessary to join the four wires A, B, C and D of each two-pair core to the Bridge in the four different ways shown in Figs. 7, 8, 9 and 10, a special switch being provided for this purpose.

Before making measurements on the cable, the Bridge itself must be balanced.

To do this, condenser No. 1 and condenser No. 2 are ~~varied~~ ^{ADJUSTED} until both the telephone receivers T_1 and T_2 are silent at the same instant. 1/28

The scales on condensers No. 1 and No. 2 are then set to read zero. These scales are graduated in micro-microfarads to read positive values when the capacity is decreased, and negative values when the capacity is increased.

Having balanced the Bridge, a two-pair core of the cable is joined to the Special Switch, and the switch set at the first position. This joins the wires of the two-pair core to the Bridge as shown in Fig. 7.

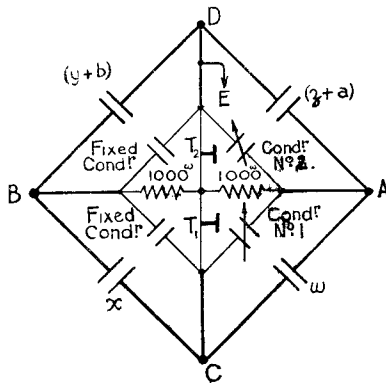
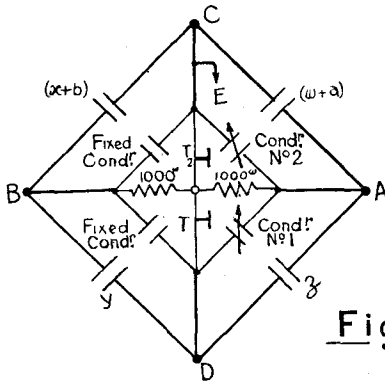

Fig. 7.

Condensers No. 1 and No. 2 are then varied until both the telephones T_1 and T_2 are silent at the same instant. Then

$$\text{Reading on Condenser No. 1} = w - x$$

$$\text{Reading on Condenser No. 2} = (z+a) - (y+b)$$



The Special Switch is then moved to position No. 2 (Fig. 8) and the bridge is again balanced.

Then,

Reading on Condenser No. 1 = $z - y$

“ “ “ “ No. 2 = $(w + a) - (x + b)$

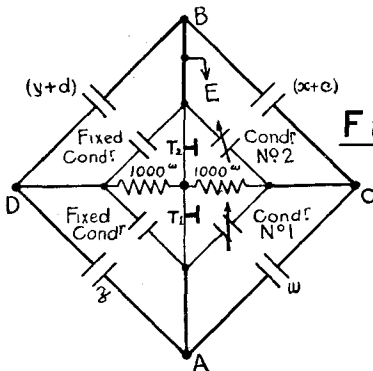

Similarly for position No. 3 of the Special Switch (Fig. 9),

Reading on Condenser No. 1 = $w - z$

“ “ “ “ No. 2 = $(x + c) - (y + d)$

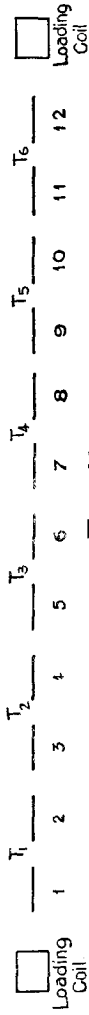

Fig. 11.

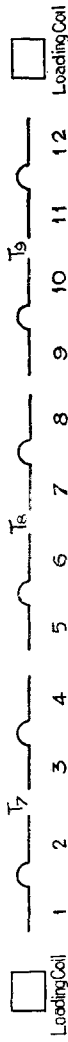

Fig. 13.

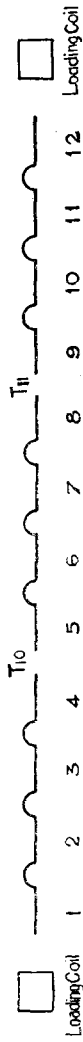

Fig. 14.

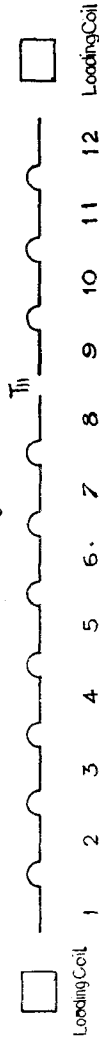

Fig. 15.

loading coils. As an example, however, consider the case in which there are 12 single lengths of cable to the loading coil section as shown in Fig. 11.

The single lengths of cable are tested at the points $T_1, T_2, T_3, T_4, T_5,$ and T_6 : lengths 1 and 2 being tested at T_1 ; lengths 3 and 4 being tested at T_2 , and so on.

The test results are recorded on Testing Schedules from which Jointing Schedules are prepared which show the jointer how the wires should be joined together.

The method of arriving at the best way of jointing the wires of two adjacent lengths together is as follows:—

Suppose on length 1 the Red core has a $(w-x)$ equal to 200 micro-microfarads, as shown on the Testing Schedule. That is,

$$(w-x)_R = +200 \text{ mmf.}$$

The testing schedule for length 2 is then examined in order to find a core with a $(w-x)$ as nearly as possible equal to 200 micro-microfarads.

Suppose on the Green core of length 2

$$(w-x)_G = +240 \text{ mmf.}$$

Then, if these two cores are joined together, A wire to A wire and B wire to B wire, the $(w-x)$ measured on the two lengths when joined together would be

$$(w-x)_R + (w-x)_G = 200 + 240 = +440 \text{ mmf.}$$

But if, when joining these two cores together, the AB wires are crossed, that is, if the A wire is joined to the B wire and the B wire to the A wire, then the $(w-x)$ measured on the two lengths when joined together would be,

$$(w-x)_R - (w-x)_G = +200 - 240 = -40 \text{ mmf.}$$

So that by crossing the wires, the capacity unbalance $(w-x)$ has been reduced to -40 micro-microfarads. It follows, of course, that when selecting cores to be joined together, all the wire to wire unbalances, $w-x, z-y, w-z, x-y$, and also the wire to earth unbalances $a-b$ and $c-d$, of each core must be taken into consideration.

The preparation of the Jointing Schedules therefore requires considerable skill and experience.

From the above it will be seen that the selection of the cores will depend upon the relative *magnitudes* of the wire to wire unbalances and the relative *magnitudes* of the wire to earth unbalances. Whether the wires of these cords are to be crossed or not will depend upon the relative *signs* of the wire to wire unbalances and the relative signs of the wire to earth unbalances. On no account must a core be "split." That is, if the A and B wires of the Red core are joined to the A and B wires of the Green core, then the C and D wires of

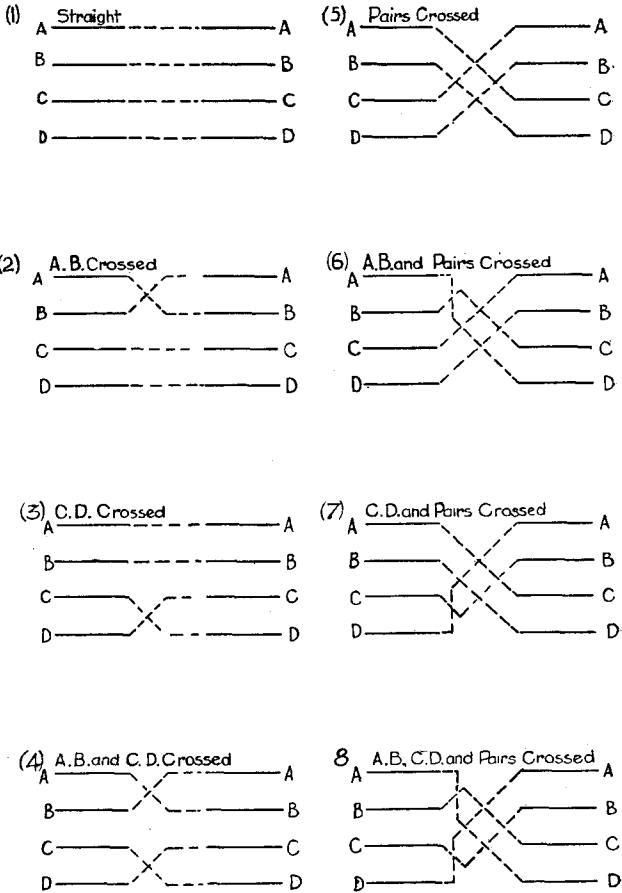

Fig.12.

the Red core *must* be joined to the C and D wires of the *same* Green core. Neither must a pair be "split." That is, if the A wire of the Red core is joined to the A wire of the Green core, then the B wire of the Red core *must* be joined to the B wire of the *same* Green core.

There are therefore eight possible ways of joining together the wires of two cores. These are shown in Fig. 12.

Having prepared the jointing schedules for the joints at each of the points $T_1, T_2, T_3, T_4, T_5,$ and T_6 (Fig. 11), the joints at these points are made and the loading coil section will then be as shown in Fig. 13.

Tests are then made on each of the two-length sections at the points $T_7, T_8,$ and T_9 .

These joints are "selected" from the test results, and jointing schedules are prepared as already described. When these joints have been made, the loading coil section will be as shown in Fig. 14.

Tests are then made at the point T_{10} , on each of the four-length sections, 1, 2, 3, 4, and 5, 6, 7, 8, and at the point T_{11} on the four length section 9, 10, 11 and 12.

The joint T_{10} is "selected" from the test results and the jointing schedule is prepared.

When this joint has been made, the loading coil section will be as shown in Fig. 15.

A final test is made at the point T_{11} on the eight-length section, 1, 2, 3, 4, 5, 6, 7, 8.

This joint is "selected" from the test results, and the jointing schedule is prepared.

When this joint has been made, the loading coil section will be completely joined up, and the wire to wire unbalances $w-x, z-y, w-z, x-y,$ and the wire to earth unbalances, $a-b$ and $c-d,$ when measured on the completed loading coil section should have very small values.

The overhearing between side circuits and between the superposed circuit and the side circuit will then be so small as to be negligible. If overhearing tests are made between any other two circuits in the loading coil section, that is, between any two circuits not in the same two-pair core, this overhearing will also be so small as to be negligible.

Each loading coil section throughout the whole cable is "balanced" in the above manner. The loading coils are then joined up, and, if overhearing tests are made on the completed cable, it will be found that the overhearing between any two circuits in the cable, whether these circuits are in the same two-pair core or not, has been almost entirely eliminated.

==== LIST OF ====

Technical Pamphlets for Workmen

(Continued)

GROUP E.

1. Automatic Telephone Systems.

GROUP F.

1. Subscribers' Apparatus C.B.
2. Subscribers' Apparatus C.B.S.
3. Subscribers' Apparatus Magneto.
4. Private Branch Exchange—C.B.
5. Private Branch Exchange—C.B. Multiple, No. 9.
6. Private Branch Exchange Magneto.
7. House Telephones.
8. Wiring of Subscribers' Premises.

GROUP G.

1. Secondary Cells, Maintenance of.
2. Power Plant for Telegraph and Telephone Purposes.
3. Maintenance of Power Plant for Telegraph and Telephone Purposes.
4. Telegraph Battery Power Distribution Boards.

GROUP H.

1. Open Line Construction, Part I.
2. Open Line Construction, Part II.
3. Open Line Maintenance.
4. Underground Construction, Part I.
5. Underground Construction, Part II.
6. Underground Maintenance.
7. Cable Balancing.
8. Power Circuit Guarding.
9. Electrolytic Action on Cable Sheaths, etc.
10. Constants of Conductors used for Telegraph and Telephone Purposes.

GROUP I.

1. Submarine Cables.

GROUP K.

1. Electric Lighfing.
2. Lifts.
3. Heating Systems.
4. Pneumatic Tube Systems.
5. Gas and Petrol Engines.

GROUP L.

1. " Safety First " for P.O. Engineering Workers.