

Telex with Teleprinter 15 having Automatic Transmission of Message Facilities

On the United Kingdom telex service, calls can be made between teleprinter installations at any time of the day or night. The installations communicate in print.

Calls can also be made to the majority of other telex installations all over the world.

The Teleprinter 15 described here can transmit messages automatically at the maximum speed of nearly 70 words a minute. This is about twice the speed achieved manually on a telex installation by a good typist, and call charges can be almost halved.



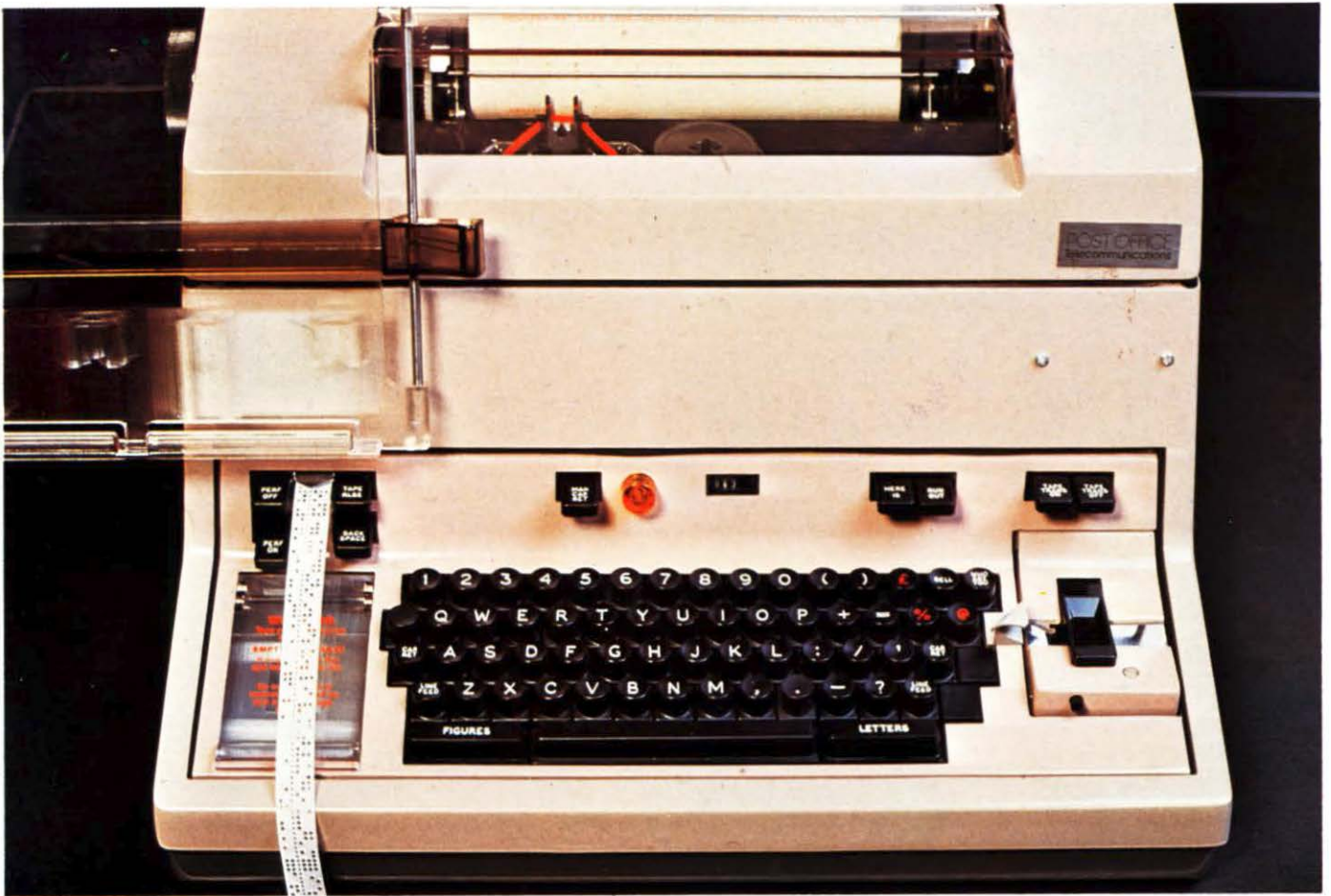

The Teleprinter keyboard

The keyboard has four banks of keys and is almost identical to that of a typewriter, except that the machine prints only in capitals, and certain keys have special functions.

Letters

After this bar has been pressed, the machine prints the capitals shown on the letter-keys as they are pressed. The figure and symbol keys are locked to avoid misoperation.

Figures

After this bar has been pressed, the machine prints the figures and symbols shown on the remaining keys as they are pressed, and allows BELL and WHO ARE YOU to be used. The letter-keys are locked to avoid misoperation.

Bell

When the machine is on FIGURES and this key is pressed, an alarm sounds at each installation.

Who Are You

When the machine is on FIGURES and this key is pressed, the 'answer-back' code which identifies the other installation, is printed by both teleprinters. This key cannot be used when transmitting automatically.

Car Ret

When pressed, the key either side of the keyboard returns the type basket to the start of a line.

Line Feed

When pressed, the key either side of the keyboard moves the paper upwards ready for the next line of type.

Space Bar

The type basket moves along one space each time the bar between FIGURES and LETTERS is pressed.

The organ-type keys above the keyboard

Man Car Ret

This key is pressed to return the type basket to the start of a line when the machine is switched off. This must be done before reloading paper or paper tape, changing the ribbon or cleaning the type face.

Here Is

When this key is pressed, the machine sends its own 'answer-back' code which is printed by both teleprinters.

Run Out

When this key is held down, the last character that was typed on the machine is printed continuously. This key enables the beginning and end of a tape to be identified with blocks of repeated perforations, and steps the message clear of the perforator for tearing off without mutilation.

Tape Trans On

When this key is pressed down, the automatic transmitter switches on, and the paper tape bearing the message passes through it to transmit the message automatically.

Tape Trans Off

When this key is pressed, the automatic transmitter switches off to stop the tape, or if the message has ended, to stop the alarm.

Perf On

When this key is pressed down, the perforator is engaged so that the message is punched on paper tape at the same time as the page copy is typed.

Perf Off

When this key is pressed, the perforator is disengaged.

Tape Rise

When this key is held down, pressure on the tape is released so that it can be pulled forward.

Back Space

Each depression of this key moves the tape in the perforator back one character to allow any errors made during tape preparation to be corrected.

The dialling unit

Four control buttons and two signalling lamps are mounted on the dialling unit.

Dial

This button is pressed to start the teleprinter, and engage the line and the equipment in the telex exchange. The green lamp glows to show when dialling can begin and remains alight as long as the installation is in use.

Clear

This button is pressed at the end of a call to switch off both teleprinters and release the line and exchange equipment.

Local

This button is pressed to start the teleprinter so that it can be used for preparing a message on tape, message copying or practice. The green lamp glows while the machine is being used.

Reset

This button is used to switch off the teleprinter after local use. It is also used to cut off the alarm signal and red lamp when a distant teleprinter operator has called for attention.

Message preparation

Before making a call in which a message is to be transmitted automatically, the paper tape must be prepared by switching on the teleprinter for LOCAL use and pressing the PERF ON key. As the message is typed, the tape is punched and the printed page copy can be checked continuously for accuracy against the original text.

Errors on the tape can be corrected as soon as they are noticed on the page copy.

A taped message can be 'played-back' on the teleprinter to ensure that it is correct.

The perforated paper tape bearing the message is then loaded into the automatic transmitter on the teleprinter, ready for sending during the call.

How it operates

Each installation has a telex number and an 'answer-back' code to identify it.

Calls are made simply by pressing the DIAL button and dialling the required number.

When the distant installation gets the call, the teleprinter starts and returns its 'answer-back' code to confirm that it is ready to receive a message.

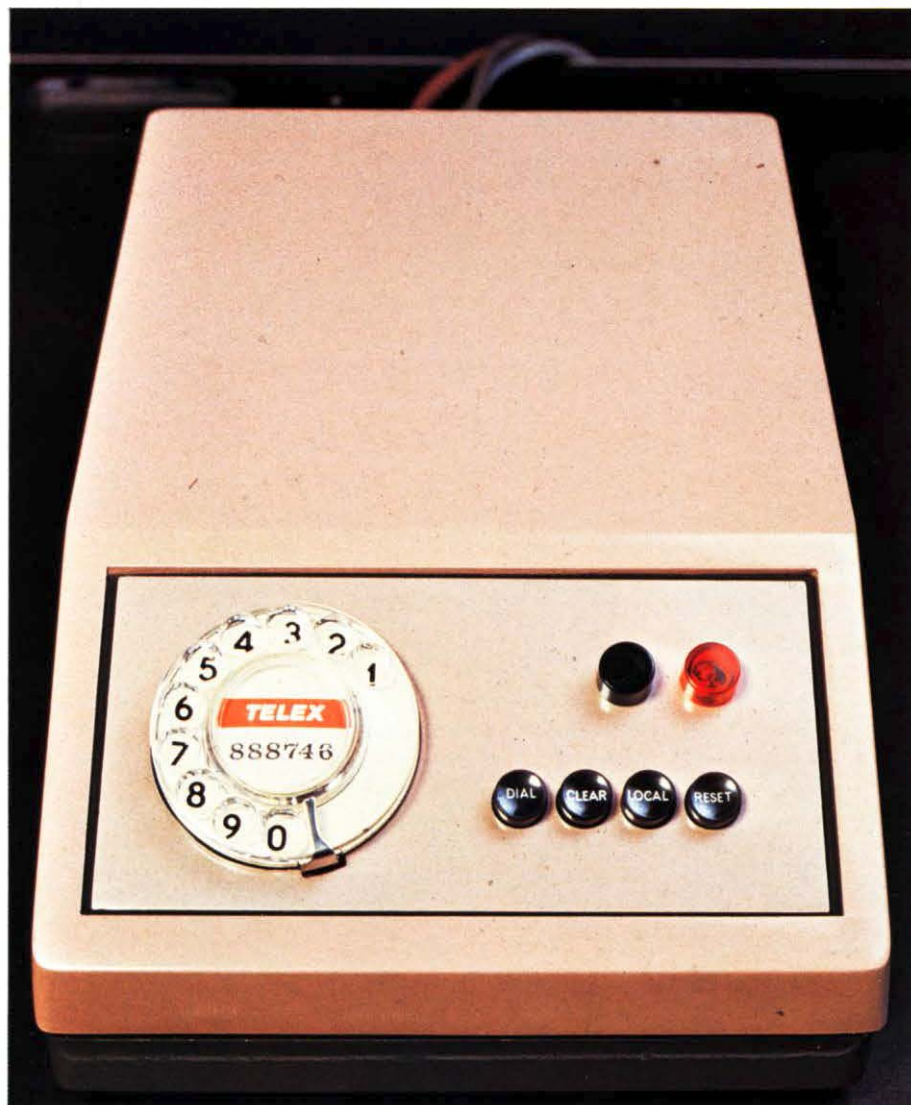

The caller presses the HERE IS key to let the distant installation know who is calling, then types and the distant installation can type back.

When required, the automatic transmitter is switched on to send the taped message at the maximum speed of the machine. The keyboard cannot be used while the automatic transmitter is in use. When the message ends, the automatic transmitter stops and this is indicated by the alarm signal and red lamp.

At any time during a call, except when the automatic transmitter is in use, either operator can attract the other's attention with the BELL key, which sounds an alarm and lights a red lamp at both installations. These signals stop when the RESET button is pressed.

At the end of a call it is usual to confirm the connexion with an exchange of 'answer-back' codes. The caller simply presses in turn the HERE IS and WHO ARE YOU keys.

The call is ended when the CLEAR button is pressed at either installation.

Facilities

All operations of the teleprinter are power-assisted, and a good typist can easily achieve 35 to 40 words a minute. The machine can be used at a maximum speed of about 70 words (400 characters or spaces) a minute, which is the speed at which messages on tape are sent.

Transmitting a message automatically shortens the duration of the call and considerably reduces the call charge.

Identical messages appear on both teleprinters of everything that is typed during the call.

The teleprinter can print in two colours if a suitable ribbon is used; for example the outgoing portion of the message can appear in red type while the incoming portion is typed in black.

Single-ply paper, or multi-ply with up to five under-copies, can be used in the teleprinter.

The paper is 216mm wide and up to 69 characters or spaces form each line. A warning lamp above the keyboard glows when 55 characters or spaces have been typed on a line.

The caller can set the line feed of his own machine for single, intermediate or double spacing.

A buzzer can be switched on, when required, to signal incoming calls. An extension alarm to a nearby room can also be provided.

Messages can be received by the installation even when the office is closed, provided that the power supply is left on, and there is sufficient paper in the machine.

An incoming call automatically starts the teleprinter, and it is switched off when the distant operator presses the CLEAR button.

Incoming calls are still received if the teleprinter is being used in LOCAL for message preparation, message copying or practice. The alarm and red light warn that the installation should be restored to normal use. After a short interval the installation is automatically restored to normal so that the call can be received.

Dimensions

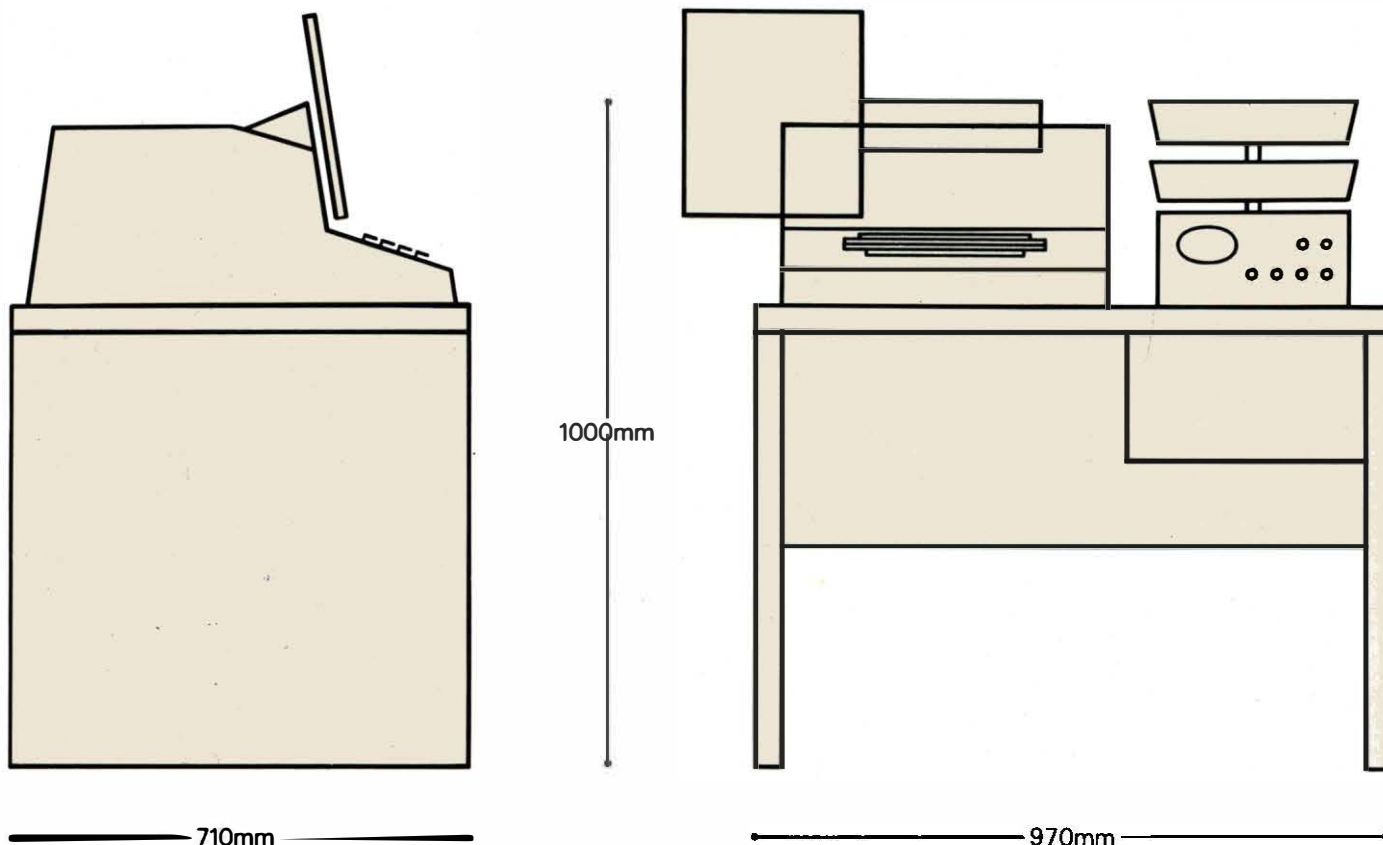

On an incoming call, the message can be produced on paper tape as well as the page copy, if required. This is useful when the message has to be relayed to another office.

A message on paper tape can be used many times to transmit to several different destinations, to produce additional page copies for local use or to make further taped messages. A heavier duty tape can be used for repetitive transmissions.

General information

The teleprinter has a sound-reducing cover with a window through which the message can be read. The cover is hinged so that the paper and paper tape can be replaced or the ink ribbon changed without difficulty.

A transparent lectern to hold the message is fixed to the front of the cover. Two message trays are supported above the dialling unit, and the table, provided with the teleprinter, contains a drawer for filing or storage purposes.

The dialling unit houses power and auxiliary apparatus, and the installation works from a mains 3-pin switched socket outlet, of at least 5-amp rating, provided by the customer.

Allowing adequate room for the operator's chair and for maintenance purposes the installation requires a floor space of not more than 1520mm by 1220mm.

The total weight of the installation is 127kgs.

The basic telex installation with Teleprinter 15 is fully described in leaflet DLG 702.

Console-mounted Teleprinter 15 installations are also available, and these are described in DLG 704.

Please note

We do our best to supply our customers with the apparatus they ask for but we may have to provide apparatus which does not accord exactly with the descriptions and illustrations in this leaflet.

Your Telephone Sales Office will gladly supply any further information or details of any changes in the information in this leaflet since it went to print. The address and telephone numbers are shown in the preface of your Telephone Directory. Information on a wide range of our services and apparatus is contained in the Green Pages section of most Telephone Directories.