

*Crown Copyright Reserved*

P W-D.19

# Post Office Engineering Department

---

## TECHNICAL PAMPHLETS FOR WORKMEN

---

*Subject :*

### **CORD REPAIRS**

ENGINEER-IN-CHIEF'S OFFICE  
1919

*(Revised 1926.)*

Reprinted, September, 1928, including correction slips to date)

- ( ,, December, 1929, ,, ,, ,, )
- ( ,, March, 1931, ,, ,, ,, )
- ( ,, April, 1933, ,, ,, ,, )
- ( ,, January, 1935, ,, ,, ,, )

== LIST OF ==  
**Technical Pamphlets for Workmen**

---

---

**GROUP A.**

1. Magnetism and Electricity.
2. Primary Batteries.
3. Technical Terms.
4. Test Boards.
5. Protective Fittings.
6. Measuring and Testing Instruments.
7. Sensitivity of Apparatus.
8. Standard List of Terms and Definitions used in Telegraphy and Telephony. (*Not on Sale.*)
9. Standard Graphical Symbols for Telegraphy, Telephony and Radio Communication. (*Not on Sale.*)

**GROUP B.**

1. Elementary Principles of Telegraphy and Systems up to Morse Duplex.
2. Telegraph Concentrators.
3. Wheatstone System. Morse Keyboard Perforators.
4. Quadruplex, Quadruplex Repeated Circuits and Telegraph Repeaters, Simplex and Duplex.
5. Hughes Type-printing Telegraph.
6. Baudot Multiplex Type-printing System.
7. Western Electric Duplex Multiplex. Murray Duplex Multiplex. Siemens and Halske Automatic Type-printing System.
8. Fire Alarm Systems.

**GROUP C.**

1. Wireless Transmission and Reception.
2. Interference with Reception of Broadcasting.

**GROUP D.**

1. Elementary Principles of Telephony.
2. Telephone Transmission. "Loading." Telephone Repeaters and Thermionic Valves.
3. Principles of Telephone Exchange Signalling.
4. Magneto Exchanges—Non-Multiple Type.
5. Magneto Exchanges—Multiple Type.
6. C.B.S. No. 1 Exchanges—Non-Multiple Type.
7. C.B.S. Exchanges—Multiple Type.
8. C.B. Exchanges—No. 9 Type.
9. C.B. Exchanges—No. 10 Type.
10. C.B. Exchanges—No. 12 Type.
11. C.B. Exchanges—22 Volts.
12. C.B. Exchanges—40 Volts.
13. Trunk Telephone Exchanges.
14. Maintenance of Manual Telephone Exchanges.
15. Telephone Testing Equipment.
16. Routine Testing for Manual Telephone Exchanges.
17. Internal Cabling and Wiring.

[Continued on page iii of Cover.]

# CORD REPAIRS

(D19)

---

*The following pamphlets in this series are of kindred interest :—*

- D.1. Elementary Principles of Telephony.**
  - D.14. Maintenance of Manual Telephone Exchanges.**
  - D.15. Telephone Testing Equipment.**
- 

## TABLE OF CONTENTS

	Page
Construction of Instrument Cords ... ..	3
Identification Colour Schemes ... ..	4
Construction of Switchboard Cords ... ..	11
Identification Colour Schemes ... ..	12
Maintenance ... ..	13
Switchboard Colour Schemes for Cords ... ..	21
Testing Procedure ... ..	21
Repairs ... ..	22
Procedure ... ..	22
Hints on Instrument Cord Repairs ... ..	23
Hints on Switchboard Cord Repairs ... ..	26
Testing Procedure for Cords after Repair ... ..	27

## **CORRECTION SLIP TABLE.**

---

The month and year of issue is printed at the end of each amendment in the Correction Slips, and the number of the slip in which any particular amendment is issued can, therefore, be traced from the date. In the case of short corrections made in manuscript, the date of issue of the slip should be noted against the correction.

The Summary portions of the Correction Slips should be completed and affixed below in numerical order.

---

# CORD REPAIRS

---

## TELEPHONE CORDS : THEIR CONSTRUCTION, MAINTENANCE AND REPAIR

It is generally acknowledged that a cord is a weak link in any chain of connections forming an electrical circuit, the weakness being greater or less according to the manipulation which the cord receives. In telephone circuits cords are employed to a greater extent and subjected to a greater amount of manipulation than in any other class of electrical circuit, and the wear and tear is correspondingly heavy. The efficiency of the telephone service therefore depends to an extraordinary extent upon a high standard of quality in design, construction, maintenance and repair of cords.

Telephone cords are divided into two main classes, *viz.*, *Instrument Cords* and *Switchboard Cords*. The former comprise all those used with telephone instruments and for miscellaneous purposes, the latter only those used for connecting together circuits on telephone switchboards and others of similar nature.

### CONSTRUCTION OF INSTRUMENT CORDS

For convenience in describing the construction of instrument cords they will be sub-divided into six groups according to the class of service they are designed for :—

A. For ordinary service as flexible connections to subscribers' telephones, and exchange operators' speaking sets. No. 222 is an example.

B. "Waterproof" cords. For service as group A, but in damp situations.

C. For outdoor service such as on linemen's portable sets, fire alarms, etc. No. 320 is an example.

D. For use on intercommunication table telephones, and in other cases where a flexible connection of moderate bulk is needed, containing twelve or more conductors.

E. For flexible connections inside telephone sets.

F. For testing devices, telegraph sets, and other purposes where a robust cord of low conductor resistance, high insulation and comparatively high current carrying capacity is needed. No. 426 is an example.

*Group A* includes the majority of instrument cords. They have tinsel conductors, insulated with a coloured silk braiding,

and then braided over with mercerized cotton. The conductors thus covered are twisted together to form two-way cordage, and plaited together to form three or more way cordage. A considerable proportion of cords at present in use are of an obsolescent type having a braiding overall. These, as a rule, are less flexible and more liable to "kink" than the plaited type.

*Group B* cords differ from *Group A* only in having rubber insulation. Instead of the coloured silk braiding there is first a lapping of fine cotton, then a lapping of pure rubber and then another lapping of fine cotton.

*Group C* cords are the same as *Group B* except that the external braidings are of a stouter and harder wearing cotton of brown colour.

The tinsel conductor for *Groups A, B, and C*, as now specified, consists of a rope of 24 tinsel threads stranded together in three groups of 8. Each thread consists of a very fine bronze ribbon wound evenly in the form of an open spiral upon a mercerized cotton thread. The resistance of the conductor is approximately  $\cdot 1\Omega$  per foot and the breaking strain about 35 lb.

*Group D* cords have conductors consisting of fifteen No. 42 S.W.G. copper wires stranded together. The insulation consists of a silk lapping, and over this there is a lapping of coloured cotton. The conductors thus covered are stranded together and then braided overall with dark green mercerized cotton.

*Group E* cords have conductor and silk insulation as for *Group D*, and then a braiding of coloured glazed cotton. They are mostly one way only, but when two-way or more, the covered conductors are twisted together.

*Group F* cords have substantial conductors consisting of fifty-five No. 42 S.W.G. copper wires stranded together, and having a resistance of approximately  $\cdot 01\Omega$  per foot. The insulating and other coverings per conductor are (1) a lapping of fine soft cotton, (2) a lapping of pure rubber, and (3) a braiding of soft coloured cotton. The conductors thus covered are stranded together with cotton wormings and braided overall with glazed marone coloured cotton.

All the stranded conductor cords are inferior to tinsel conductor cords as regards ability to withstand handling and the consequent wear and tear.

#### *Identification Colour Schemes.*

There are two colour schemes applied in the construction of instrument cords, one for identifying the manufacturer, the other for distinguishing the conductors. The first consists of

a few threads of a special colour running through the external covering. A particular colour is allotted to each manufacturer, and this enables the source of supply to be traced when desired. The second scheme provides for the covering on each conductor to be coloured as follows :—

<i>Number of Conductors.</i>	<i>Colour of Cords.</i>
1 ...	Green.
2 ...	Green, Red.
3 ...	Green, Red, White.
4 ...	Green, Red, White, Blue.
5 ...	Green, Red, White, Blue, Orange.
6 ...	Green, Red, White, Blue, Orange, Black.
7 ...	Green, Red, White, Blue, Orange, Black, Brown.
8 ...	Green, Red, White, Blue, Orange, Black, Brown, Slate.
9 to 15.	Colours as above, plus Green-Red, Green-White, Green-Blue, etc.
16 to 21.	Colours as for 15 conductors, plus Red-White, Red-Blue, Red-Orange, etc.
22 to 26.	Colours as for 21 conductors, plus White-Blue, White-Orange, etc.
27 and upwards.	Colours as for 26 conductors, plus Blue-Orange, Blue-Black, Blue-Brown, etc., in continuation of the scheme.

The colour scheme is applied thus :—

In Group *A* cords. To the silk braiding.

In Group *B* and *C* cords. To the cotton lapping over the rubber.

In Group *D* cords. To the cotton lapping.

In Group *E* cords. To the cotton braiding.

In Group *F* cords. To the cotton braiding over the rubber.

Group *E* cords are an exception to the general colour scheme inasmuch as they have to conform to the wiring colour schemes of the instruments for which they are respectively intended.

Cords for microtelephones and operators' sets have the receiver connections Red and Green, and the transmitter connections White and Blue. If there is a key or switch in the transmitter circuit, the connection to it is Blue.

In Figures 1 to 6 are shown typical cords of each group, dissected to illustrate the various forms of up-to-date

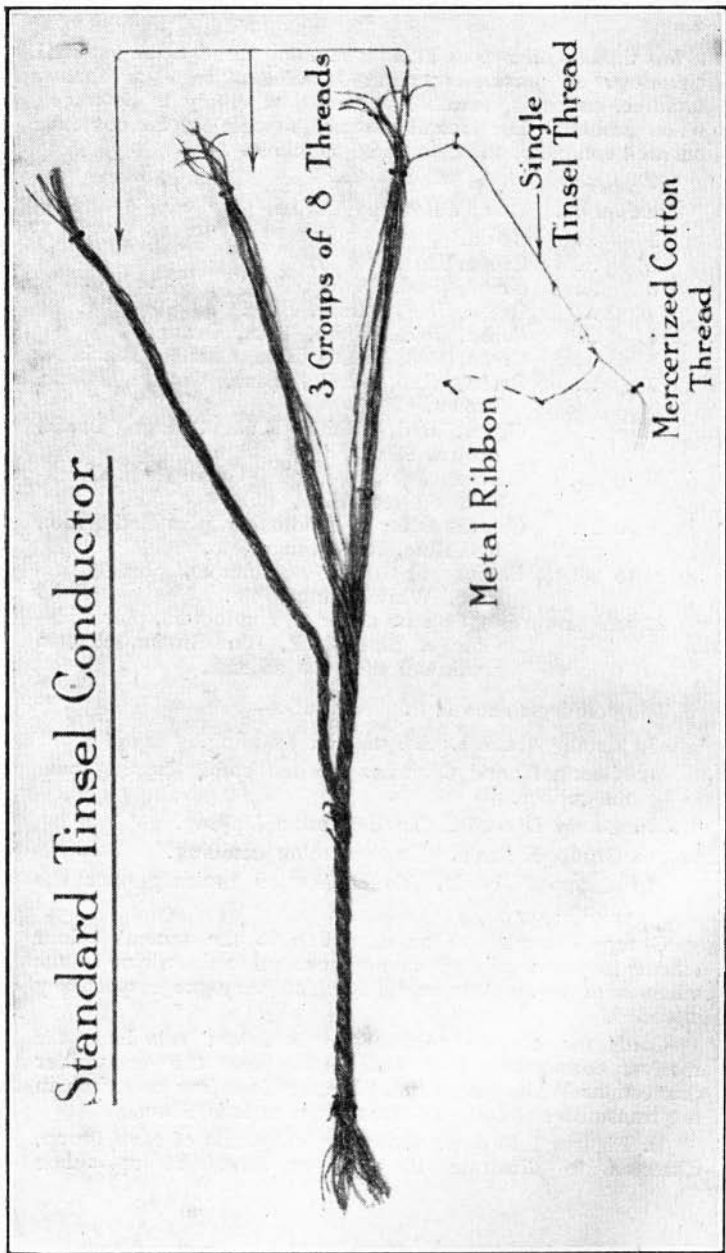

Fig. 1.



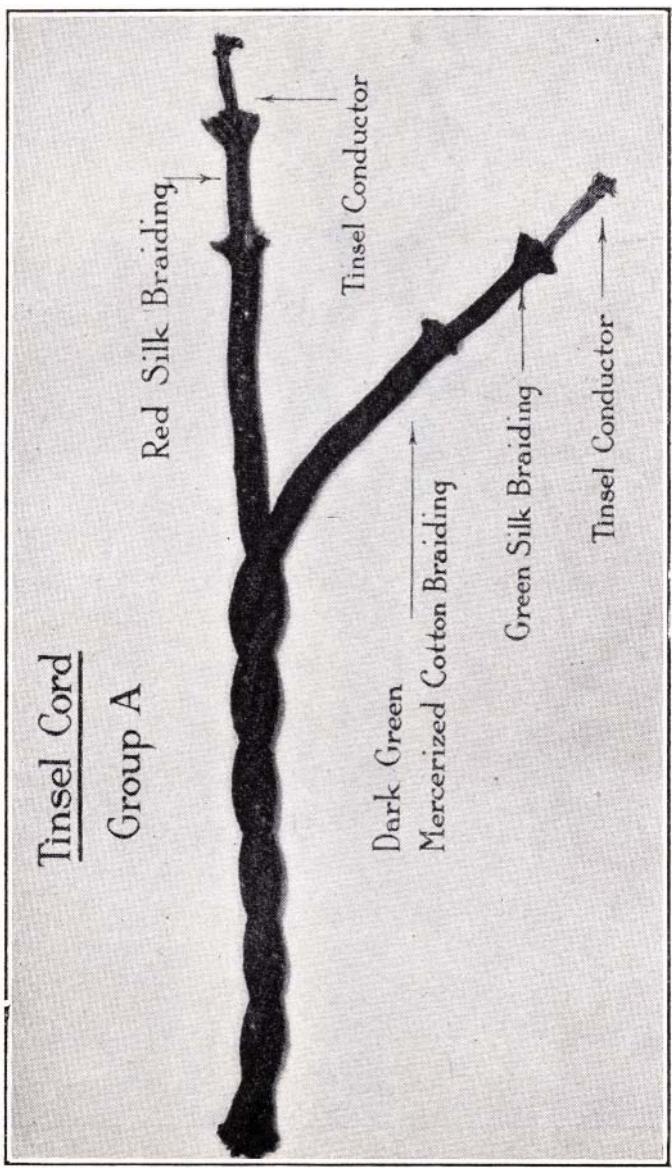

Fig. 2.

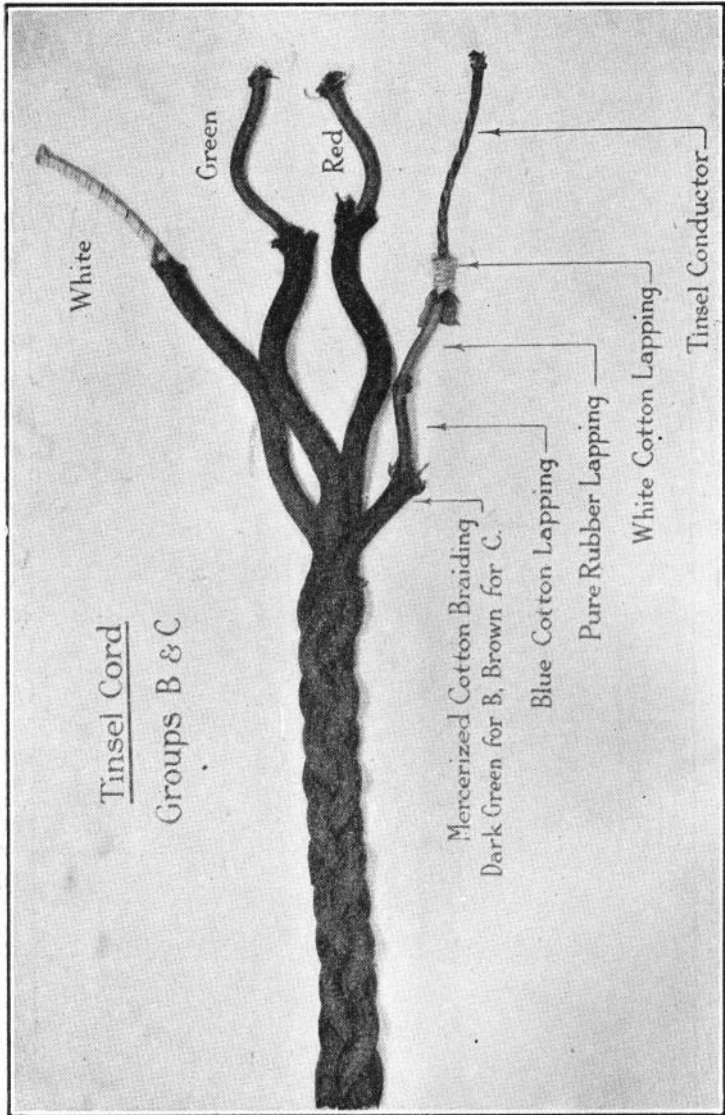

Fig. 3.

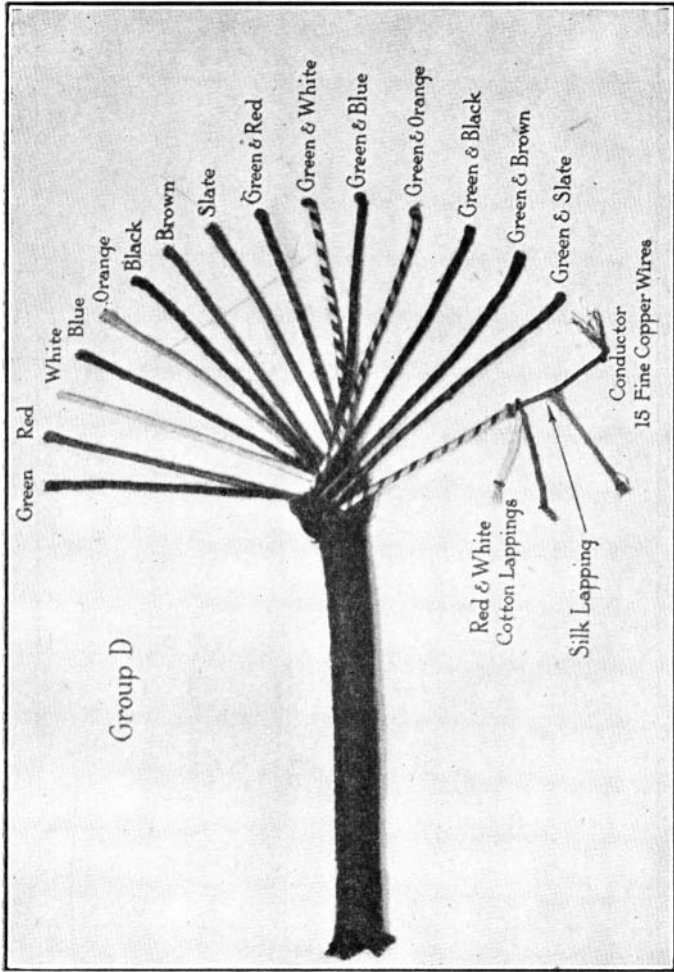

Fig. 4.

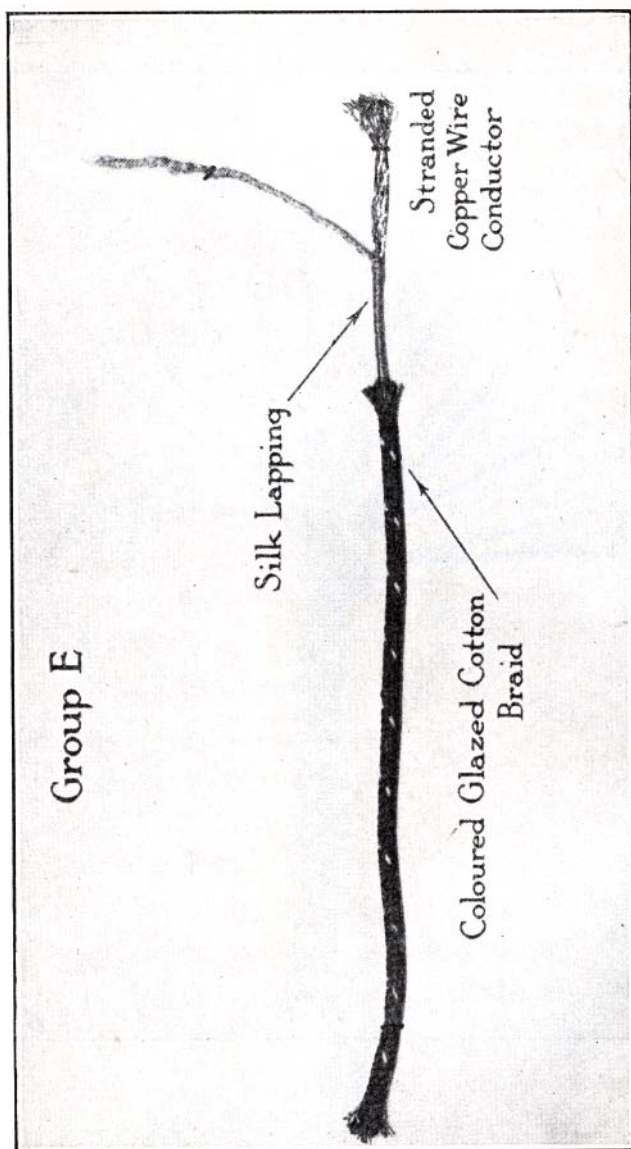

Fig. 5.

construction as described. Many cords of obsolete construction are, however, in use, and will be retained so long as they give good service.

The make-off of ends will be described later in connection with Repairs.

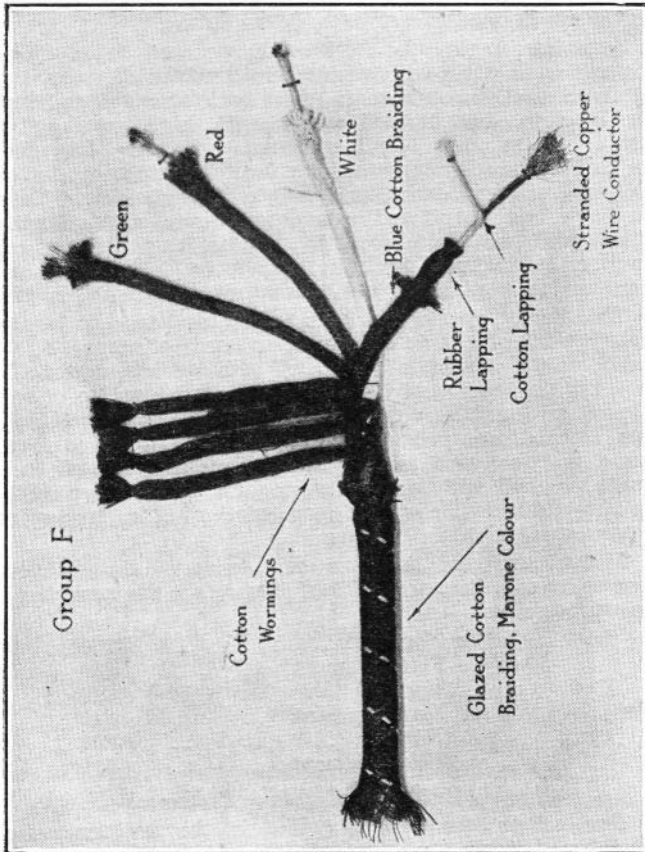

Fig. 6.

### CONSTRUCTION OF SWITCHBOARD CORDS

The switchboard cord has been the subject of much attention at the hands of inventors and the types have been

many and varied. It must be designed to withstand severe handling and to combine a high degree of flexibility with low conductor resistance, good insulation and long life. At one time the construction in general favour was braided tinsel conductors, silk covered and braided with cotton, laid up side by side, lightly bound together with a few threads of cotton, then served with a protecting spiral of hard brass wire, and finally braided overall with glazed cotton.

At a later period the steel conductor cord found much favour. In this type the conductors consisted of concentric spirals of steel ribbon insulated from each other by means of silk lappings, and braided overall with hard wearing flax thread. These cords had the advantage of very long life, but had the disadvantages of poor flexibility, high conductor resistance and impedance, and danger of overheating. They have now been abandoned in favour of improved tinsel cords which, while not quite equal to them in length of life, are superior as regards flexibility, conductor resistance, etc. Considerable numbers of steel conductor cords are still in use.

The present standard switchboard cords have conductors exactly similar to those in instrument cords of groups A, B, and C. Each conductor is insulated with two lappings of silk one over the other, and then covered with a braiding of soft coloured cotton. In two and three-way cords, the conductors thus covered are twisted together with cotton wormings, bound with an open lapping of fine soft cotton, and then braided overall with glazed cotton. Except in short cords, the plug end is double braided for a length of 12 in., by way of reinforcement to withstand handling.

Switchboard cords are now made to very definite dimensions as regards diameters. The following are the maxima for the various sizes :—

One Conductor, Normal	...	...	...	.200 in.
"    "    Reinforcement	...	...	...	.230 "
Two    "    Normal	...	...	...	.210 "
"    "    Reinforcement	...	...	...	.240 "
Three    "    Normal	...	...	...	.210 "
"    "    Reinforcement	...	...	...	.270 "

#### *Identification Colour Schemes.*

Two colour schemes are applied in the manufacture of switchboard cords, *viz.*, manufacturer identification, and conductor identification. The manufacturer's identification colour is shown by the main binding at the fastener end of the cord. The conductor identification colours are White, Blue and Red, and they are applied to the cotton braiding on the conductors. White is the colour for single conductors; White

and Blue for two conductors; and White, Blue and Red for three conductors. The order of connection to plugs is as follows :—

Single-way plugs; White.

Two-way plugs; White to tip, Blue to sleeve.

Three-way plugs; White to tip, Blue to ring, Red to sleeve.

Figures 7 to 9 are illustrations of pieces of standard switch-board cordage dissected to show the construction.

Ends and Bindings will be described in connection with Repairs.

### MAINTENANCE.

There are three matters for consideration in connection with the maintenance of cords, *viz.* :—

1. Reduction and prevention of wear and tear.
2. Ways and means of anticipating breakdowns.
3. Prompt and efficient repairs.

In connection with 1 and 2, it will be convenient first of all to consider the causes of breakdown, the principal of which are as follows :—

- (a) Dragging, kinking and twisting.
- (b) Dropping receivers and hand sets.
- (c) Pushing in and pulling out plugs by means of the cords attached.
- (d) Neglect and ineffective use of strain cord.
- (e) Neglect to use available protective devices where needed.
- (f) Use of unsuitable cords.
- (g) Use of pulleyweights too heavy for cords on which they are fitted.
- (h) Pulleyweights and pulleys not running freely.
- (j) Unskilled and improper fitting of cords to switchboard plugs.
- (k) Weak tinsel.

Instrument cords, especially receiver cords and those connecting table telephones to terminal blocks, are apt to become kinked and twisted under ordinary conditions of use. The effect is to put undue strain on the conductors, gradually taking the "nature" out of the metal until it becomes brittle

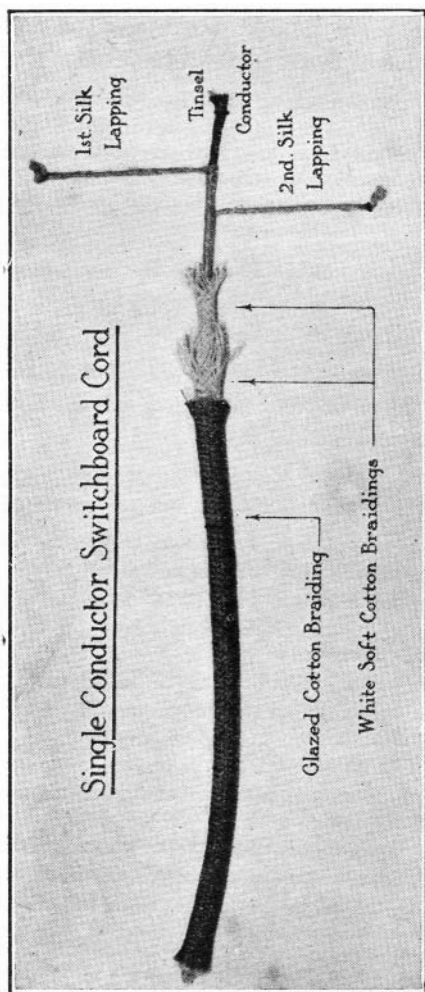

Fig. 7.



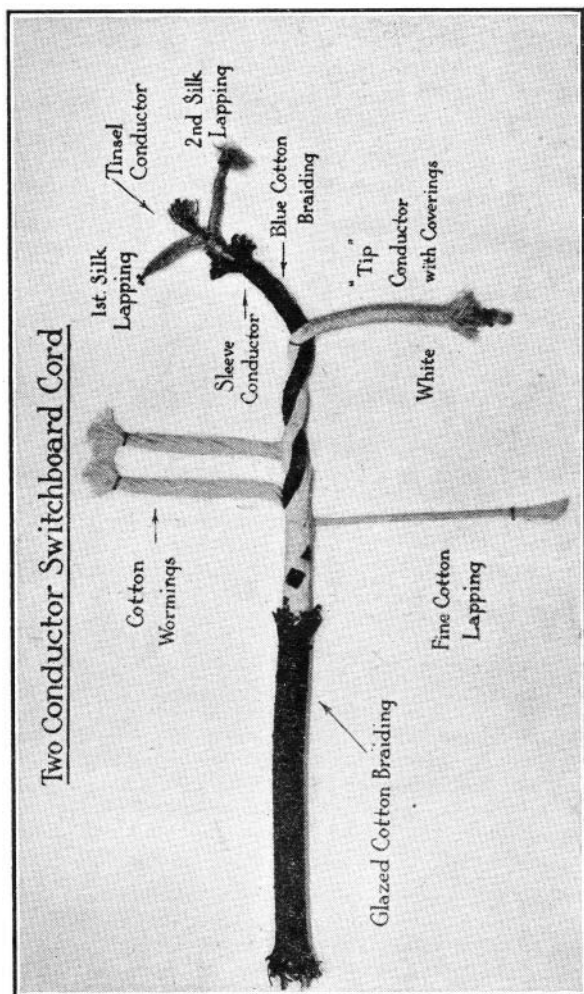

Fig. 8.

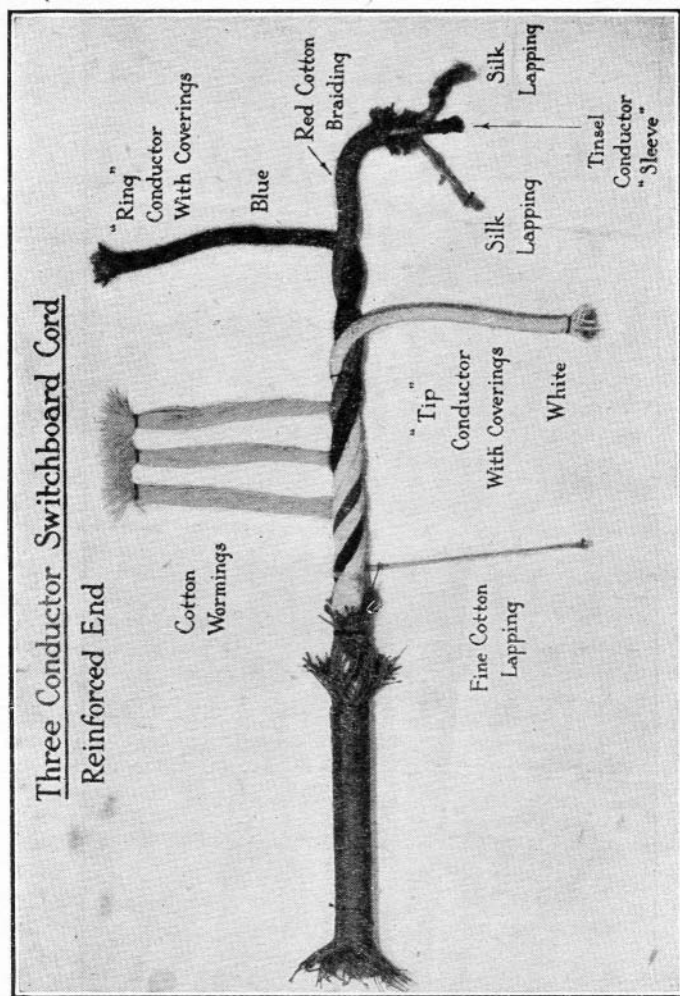

Fig. 9.

and breaks. The dropping of a hand receiver or other heavy piece of apparatus puts a sudden strain upon the attached cord which may be beyond its breaking point. Dragging table telephones along by their cords is a habit known to exist among some subscribers. Pulling plugs out by their cords, and pushing plugs home by pressing on the cords with the thumb (*see* Form TE 320) are habits to which operators are sometimes addicted. All these practices rapidly wear down the "nature" of the metal in the conductors to breaking point and should be discouraged. In the training of operators this matter is given special attention.

The fitting of the strain cord is a small item, but does not always receive proper attention. Although obviously provided to relieve the connections from strain, it is sometimes not used at all, but more often is fitted in such a way as to be ineffective, owing to insufficient allowance being made for stretching, and knots being tied that gradually slip.

As would naturally be expected, the more usual points of breakdown in cords are where they are subjected most frequently to strain and sharp bends, *viz.*, within a few inches of the points of attachment to plugs, receivers, hand sets and breast-plate transmitters. For the purpose of additional protection to instrument cords at these points, leather sleeves are provided, and are recommended for use wherever they can be employed. They are known as "Sleeves, Leather No. 1, 2 and 3" and are intended primarily for use with instrument plugs. No. 2 and No. 3 are plain tubes with several transverse slits at one end and are suitable for four, five and six-prong plugs, No. 2 being for the 4-prong, and No. 3 for the 5 and 6-prong plugs. These sleeves are drawn over the cords, the plain end being clamped under the bridge of the plug, and the other end bound to the cord, over the slits, with the regular binding thread. No. 1 is suitable for the concentric type of plug (No. 404) and has one end thickened. This sleeve is drawn over the cord and through the plug cover so that the thickened end is inside the cover and cannot be pulled through. The other end is bound to the cord as before. Figures 10, 11 and 12 show these fitments attached.

Much trouble can often be saved by using cords best suited to the conditions prevailing. For instance, "water-proof" cords should be used on instruments in markets, fish shops and other places where they are liable to be used by persons with wet hands, also in exposed and damp situations generally. Makeshifts should be avoided as far as possible even as temporary measures, especially switchboard cords not properly fitting the plug attached to them.

Pulleyweights affect the life of switchboard cords to a very considerable extent, any weight beyond that absolutely necessary to restore the cord being highly detrimental. Steel conductor cords, on account of their stiffness, require pulleyweights weighing 16 oz. for single and 36 oz. for double suspension. The standards for tinsel conductor cords are 9 oz. and 24 oz. respectively.

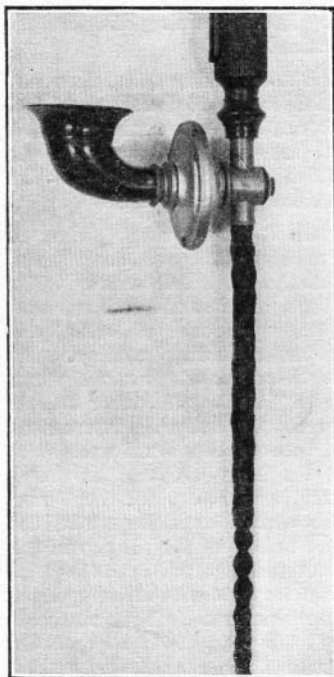

Fig. 10.

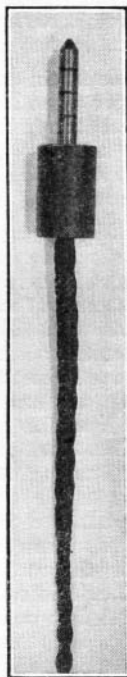

Fig. 11.



Fig. 12.

Friction in pulleys and pulleyweights is a possible source of trouble to be watched for. The warping of wood pulleys, burring of metal edges, and wearing of bearings cause pulleys to foul the sides of their casings, to jam and to become noisy. Lead dust worn off the corners of lead weights by the falling of one upon another will sometimes get in the bearings and cause the pulleys to stick. These faults produce unnecessary

wear of the overall braiding of the cords and also prevent them from restoring properly. The older types of weight are more liable to these defects than the present standards, which are

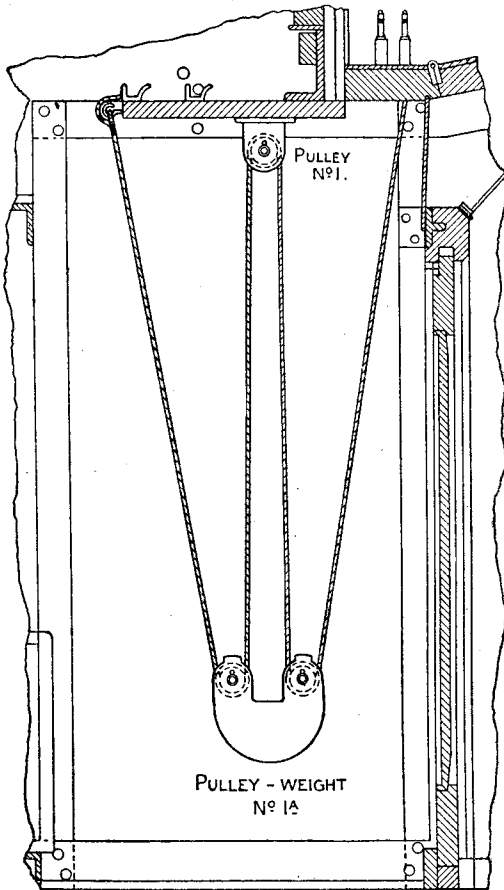

Fig. 13.

steel cased with composition or metal wheels (non-warping); they have large bearings, and are provided with lubricating holes.

There are two methods of suspension in use for long cords in exchanges, known respectively as the "horizontal" and the "vertical." They are shown in Figures 13 and 14. The horizontal system, which is the older, has a disadvantage in

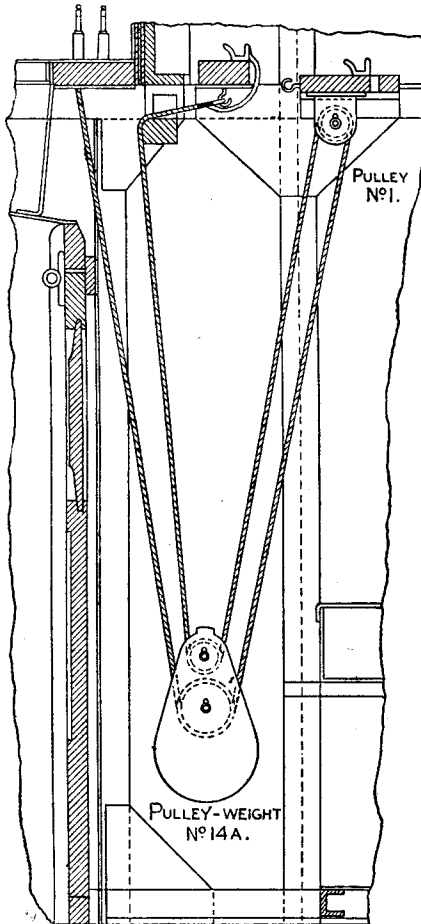

Fig. 14.

that the pulleyweights rock when the cords are drawn up or restored. This has a tendency to set them swaying, with the result that they foul each other and the cords may become

entangled. Periodical inspection and lubrication to ensure free running will generally prevent any trouble. The vertical system is free from the disadvantage just mentioned, and the weights move up and down quietly without any tilt. The practice should be adopted of lubricating all pulleys and pulleyweights sufficiently, but not excessively.

Weak tinsel has, in the past, been at times the cause of high maintenance costs on account of short life. This has been generally due, not to poor, but to unsuitable material, the character of which cannot be detected except by elaborate tests. The importance of the matter has led to a test, representing a life test, being imposed on all types of cords with standard tinsel conductor, when received from contractors. The test is specified as follows :—

“ The conductor to be gripped at two points  $\frac{7}{8}$  in. apart which shall be made to approach each other to a distance of  $\frac{3}{8}$  in. apart and then recede to their original positions, the movement being in a straight line and at a speed of 250 reciprocations per minute. The conductor to withstand without fracture of the metal on any thread a repetition of this operation 2,000 times.”

#### *Switchboard Colour Schemes for Cords.*

Switchboard cords are supplied in various colours in order that (except on very small boards) no two adjacent cords shall be of the same colour. The adoption of a colour sequence in fitting cords facilitates operating by enabling the cords to be more readily distinguished, the advantage being greater as the traffic increases. The general practice is as follows :—

A six-colour scheme with a sequence of Black, Red, Green, Yellow, Blue and Neutral, on busy Order Wire “ B ” positions at C.B. exchanges.

A four-colour scheme with a sequence of Black, Red, Green and Neutral on less busy Order Wire “ B ” positions at C.B. exchanges, also upon “ A ” positions generally, single cord Non-Order Wire “ B ” positions, double cord “ B ” positions, and on C.B.S. and Magneto multiple exchanges.

A two-colour scheme, with a sequence of Black and Red, upon C.B.S. and Magneto non-multiple exchanges, and upon P.B.X. boards.

#### *Testing Procedure.*

By regular and periodical testing faulty cords can often be detected before they break down completely. Cords, especially those of the tinsel type, do not as a rule become disconnected suddenly. The process is a gradual one, the

strands breaking one by one. During this period the cord becomes "noisy," and this noise heard on the line is the most general indication of a cord fault.

It is now the practice to provide cord testing facilities at all exchanges where telephonists are employed by the Post Office. The usual facilities consist of circuits one per two positions, terminating in jacks. Cords are tested by inserting the attached plugs into these jacks and then shaking the cords. If there is a faulty conductor or intermittent connection, a scraping noise, varying with the shaking, is heard in the operator's receiver when the speaking key (if any) is thrown, and on C.B. and C.B.S. boards further indications may be given by the behaviour of the supervisory signals. The reader is referred to Loose Leaf Diagrams K. 1700, K. 1718, L. 801, L. 813 and L. 815 for the standard cord testing circuits. Shaking tests are carried out primarily by the traffic staff, and faults reported to the engineering staff. In the larger exchanges, the cord tests form part of the routine tests carried out every morning before the traffic of the day begins. Cord circuits found to be faulty are indicated by "out-of-order" sleeves. These are insulating split sleeves which are slipped on to the plugs, and, in addition to serving as markers, prevent the plugs from being unintentionally used.

Instrument cords should receive attention on each inspection of a subscriber's instrument. On C.B. and C.B.S. systems the receiver and connecting cords can readily be tested by shaking the cords while listening on the line. On Magneto systems the faultsman may ask the exchange operator to connect the line temporarily to the section cord test jack. The instrument cords can then be tested as in the previous method. An alternative plan is to disconnect the receiver and cord from the instrument and connect them in series with a single cell, shaking the cord whilst listening on the receiver.

## REPAIRS.

**Procedure.**—The repair of cords of all types is undertaken at centres established specially for the purpose, generally at the larger exchanges.

At the smaller exchanges which are not cord-repairing centres and where the number of repairs is very small, the work done in front of the switchboard in such a manner as not to hamper the operators.

In the cases of subscribers' outfits and outlying sub-exchanges, it is most convenient to undertake only very minor repairs, changing cords requiring anything further done to them, and sending them to the local cord-repairing centre.



At large exchanges, the normal switchboard cord repairs are carried out on the site, but at the rear of the sections, so that the work can be done out of the way of the operators. In order that the cords may be extended through to the rear, holes (usually one per every alternate position) are drilled in the front of the board, a little way above the plug shelf, bushed at the front with brass or ebonite, and provided with tubes at the back to keep the plugs and cords clear of jack, cord fastener, and other connections. The plugs and cords to be repaired are passed through these holes and tubes from the front.

When repairs are necessary to plugs or cords on Coder Call Indicator positions, care should be taken to disconnect the cord at the fastener before it is passed through the cord repair tube. Failure to observe this may result in lost calls.

For repairs on site, it is very convenient to have travelling cord-repairing tables equipped with plugging tools and having suitable accommodation for the accessories needed. Figure 15 shows such a table.

A useful cord repairing box is provided for cord-repairing centres and is shown in Figure 16. It has compartments for the various binding materials, screws, tags and other items generally needed.

**Hints on Instrument Cord Repairs.**—(a) E-in-C's Drawing No. 10066 gives dimensions and details of standard ends and bindings for instrument cords and is available at all cord-repairing centres.

(b) In making loop ends, the coverings are drawn back to expose sufficient length of conductor. The part of the latter to form the loop is then closely and evenly bound with tinned wire. After this the loop is formed round a mandrel of the correct diameter and the end of the conductor tightly bound in with tinned copper wire to prevent slipping, the coverings are drawn forward again and finally bound tightly and evenly with waxed silk thread.

(c) The waxed silk end bindings should be of the correct conductor identification colour to prevent confusion when connecting the cord to an instrument.

(d) Soldered connections to tinsel conductors should only be made where this method is unavoidable. Considerable skill is required to make good soldered joints to tinsel. A solder of very low fusing point is needed, and overheating has to be guarded against or the tinsel will be burned. The only flux admissible is resin. The solder should flow and "take" well, or a "dry" joint will be the result. The best solder for this work has the composition Bismuth 50 per cent., Tin 31.25 per cent., Lead 18.75 per cent.

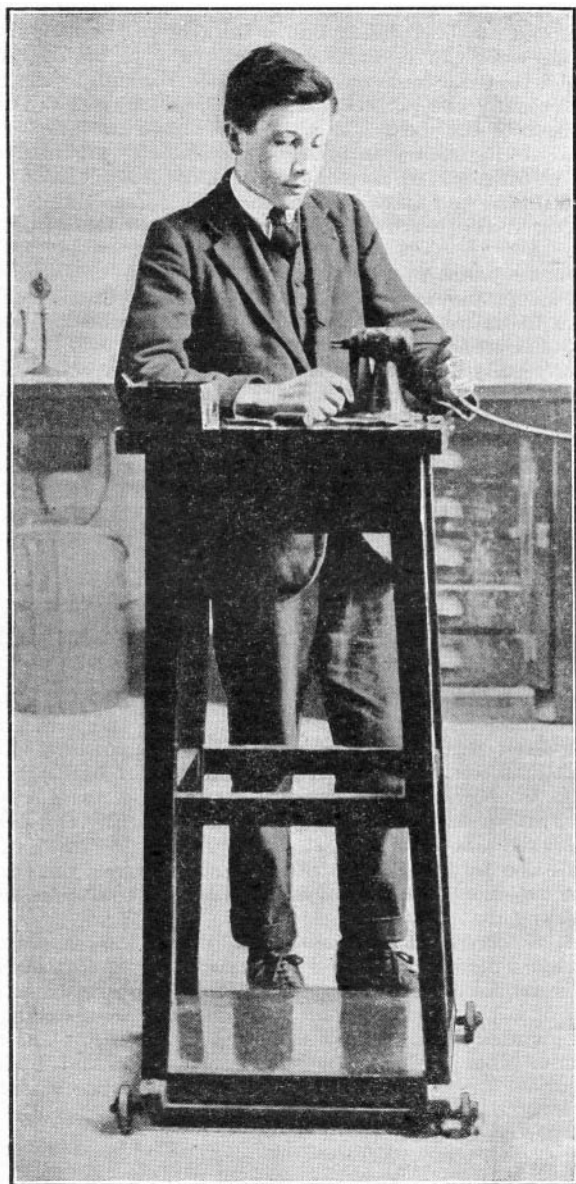

Fig. 15.

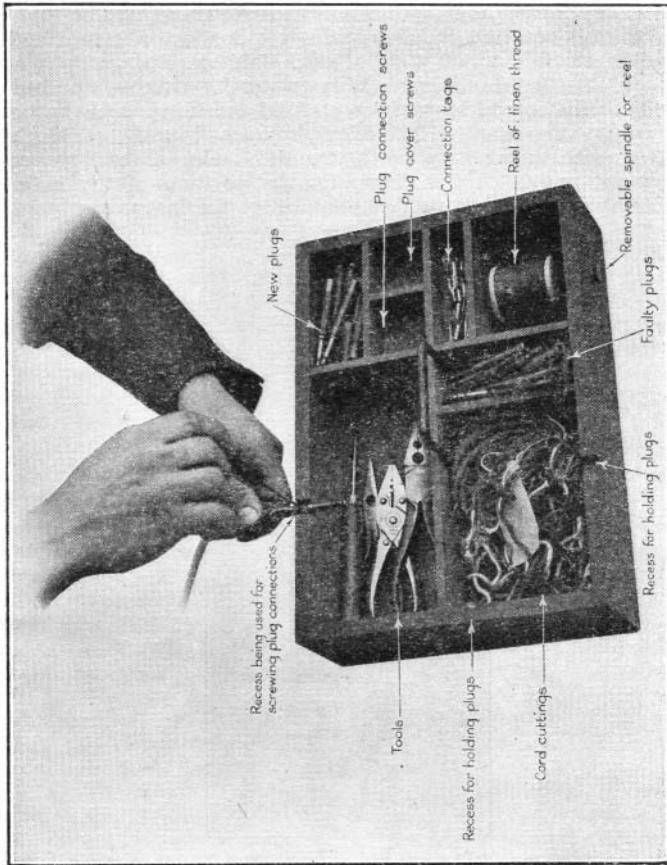

Fig. 16.

(e) Clinch joints should be well closed, with the teeth of the tags turned inwards so as to grip the conductor. In using the clinching pliers (Tool, Instrument No. 82, *see* Figure 17) the square hole should be used to close the tag round the conductor followed by the use of the correct size of shaped hole as marked on the tool itself, for finishing to size and turning in the points.

(f) Cords having the outer covering considerably worn are not worth repairing, and even a local worn place near one end

should be cut out when the cord is repaired. As a rule the covering outlasts the conductor, and it is safe to assume that, where the covering is much worn, the conductor is near the end of its life.

(g) Small "home made" templates for making up cord ends to the correct lengths are of great assistance, and can be made up very simply. For example, a small hardwood block fitted with metal pins (with rounded ends) at the proper spacing, and a clip or clamp for the position of the main binding is all that is needed for most of the instrument cord



Fig. 17.

ends. E-in-C's Drawings Nos. 10068 to 10074 inclusive, held at the repair centres, show the dimensions of ends, etc.

(h) In cutting out a conductor fault, at least half an inch beyond the fault should be cut away in order to remove strained metal which would soon break down again.

**Hints on Switchboard Cord Repairs.**—(j) E-in-C's Drawing No. 10055 gives dimensions and details of standard ends and bindings for switchboard cords. E-in-C's Drawing No. 10085 gives main dimensions. These are available at all cord-repairing centres.

(k) Not a little skill is required to make and fit a good plug end, especially if the work has to be done without the aid of cord-plugging tools. The cord, after having been cut back about half an inch clear of the fault, is bared of its overall coverings so as to expose a sufficient length of covered conductors. The main binding or bulb for screwing into the plug has to be made even and tight, firmly securing the overall coverings and also the wormings, and well stitched so that it will not burst while being screwed in. This point is of great importance, as the proper making of the bulb is essential if a firm grip is to be secured on the plug. Should the cord turn easily in the plug the conductors to the screw connections of the plug will be strained and damaged. Moreover, in the case of three-way cords, the connection of the third conductor to the sleeve of the plug may be unsatisfactory and give rise to operating difficulty. The dimensions of this binding must agree with the drawing. The tags are required to be very neatly and carefully fitted, and the clinching done as described in paragraph (e).

(l) Templates as mentioned in paragraph (g), with the addition of gauges for diameters of bulbs at plug ends, are strongly recommended for making up switchboard cord ends.

(m) Considerable care is required to screw a cord into its plug by hand, and the life may be very much shortened (by strangulation) if too much force is exerted and in the wrong place. This danger is reduced by the use of the cord plugging tools (*see* Figures 18 and 19) such as are provided at cord-repairing centres. The tool shown in Figure 18 is fitted on travelling tables. By means of these tools the cord and plug can be properly gripped, the plug being fitted in the chuck and the cord held just sufficiently tightly to prevent rotation when the chuck is revolved. As far as possible the bulb should be held, not the ordinary covering of the cord.

(n) The conductors must be securely connected. Those used in the speaking circuit must always be fixed by screws. The only conductor which it is permissible to connect friction tight between the bulb of the cord and the sleeve of the plug is the third conductor in a three-way cord.

(o) Cords, after having been repaired to the full extent of the reinforcement, can be cut down and utilized for wall switchboards.

(p) Cords with worn overall coverings should be treated as recommended in paragraph (f).

**Testing Procedure for Cords after Repair.**—The standard arrangement for testing cords removed from the switchboard is shown in E-in-C's Loose Leaf Diagram T. 109, the method followed being indicated thereon.

An additional method is in use in mechanics' shops and cord-repairing centres. It consists of a strip of jacks suitably mounted and connected up to a ringing lead with a magneto bell or buzzer in circuit, the jacks being wired as follows :—



Fig. 18.

Jack No. 1. Tip and Ring connected to bell and generator.  
Jack No. 2. Tip and Sleeve connected to bell and generator.  
Jack No. 3. Ring and Sleeve connected to bell and generator.

A continuity test is obtained by connecting together the tags of the cord and plugging into the jacks in succession. A buzz on each insertion should result.

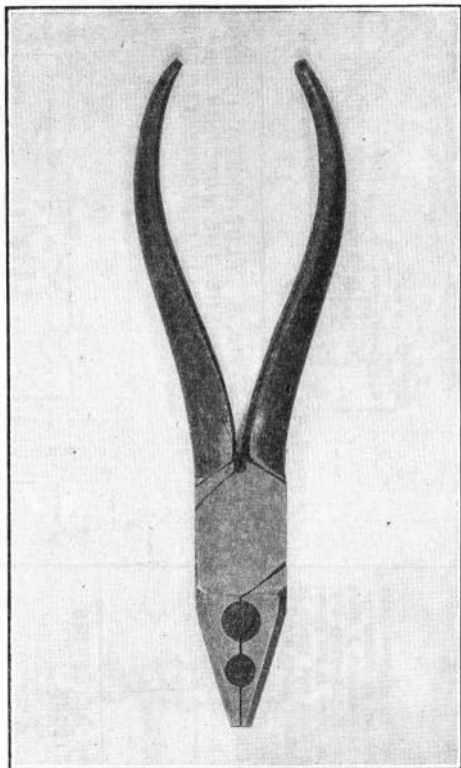

Fig. 19.

The test for contact and insulation is obtained by separating the tags and plugging-in again as before. In this case no signal should be received on the bell or buzzer. The switchboard operator concerned should be asked to make a "shake test" after the refitting of a cord in the switchboard, to ensure that it is entirely free from noise before being used for service.

# C.B. Nos. 1, 10 & 12 EXCHANGES. 22V. OR 40V. SYSTEMS. CORD TESTING CIRCUITS.

K.1700<sup>B</sup> 3.5.26  
C.B.915E.

FIG. 1. SUBSCRIBERS' ANS. & JACK-ENDED JUNC. POSITIONS AND MONITORS' DESKS.



Fig. 1 is also used as a non-operate test for effective meter on positions. At positions where the 3rd conductor res. between subs. ans. jacks and meter rack exceeds 5 ohms "X" at 22v. exchanges, will be equal to the excess over 5 ohms, and at 40v. exchanges will be equal to the excess over 5 ohms plus 20 ohms. No less than two spools in parallel must be used. Spools in parallel must be equal in res. to each other.

FIG. 2. JACK-ENDED TRUNK POSITIONS.



FIG. 3. ELECTROPHONE & TESTING OPERATORS POSITIONS.

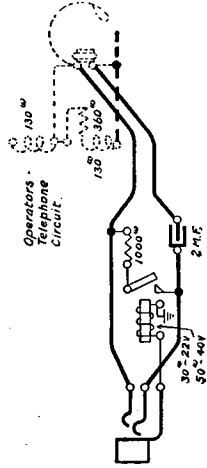
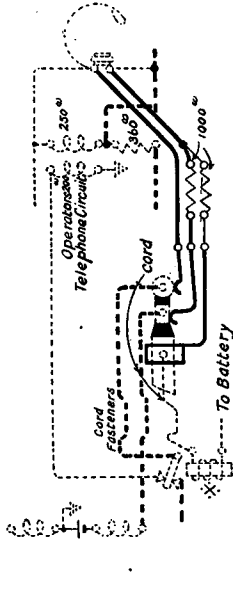
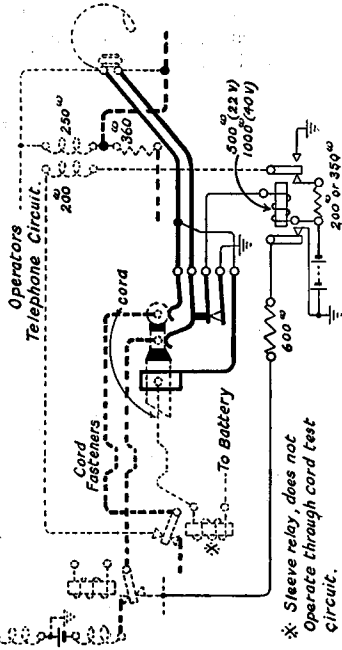

FIG. 4. PLUG-ENDED JUNCTION POSITION WHERE THE JUNC. "B" LINES ARE NORMALLY CONNECTED TO BATTERY.



Dotted portion represents Junction under test.

FIG. 5. PLUG-ENDED JUNCTION POSITION WHERE THE JUNCTION "B" LINES ARE NORMALLY DISCONNECTED FROM BATTERY.





# C.B. Nos. 1 & 10 EXCHANGES. 22v. & 40v. SYSTEMS. ROUTINE TEST CIRCUIT.

K.1718<sup>B</sup> 3,4,28  
C.B. 1295 B.

## FOR TESTING OBSERVATION CIRCUIT CORDS IN CONJUNCTION WITH TESTER No. 6.

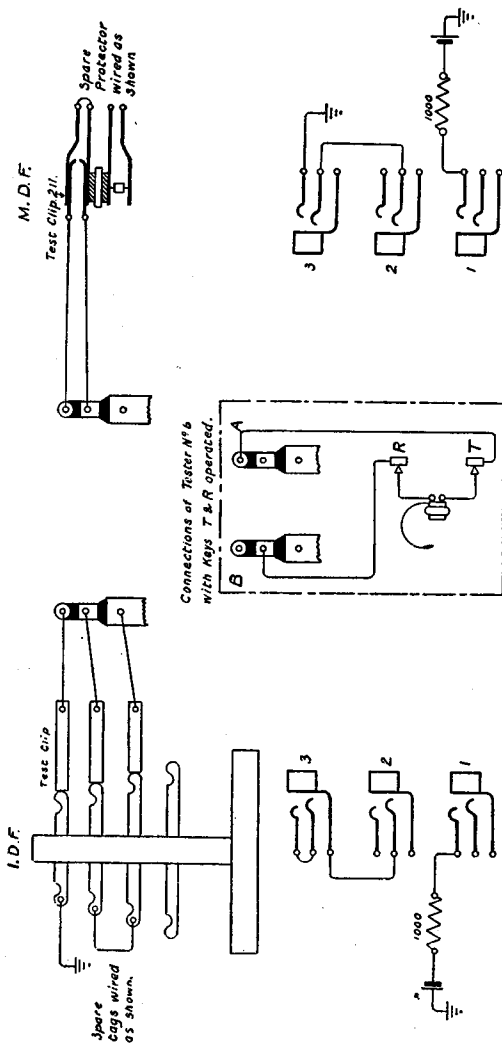

### METHOD OF TEST.

1. Connect clip end of cord under test to the testing tags and plug into Jack.
2. Insert plug A of Tester No. 6 into Jack 1 and plug B into Jack 2.
3. Depress Keys T & R of Tester and a "click" should be heard in the receiver to indicate continuity.
4. Make "shake test" whilst both Keys T & R are depressed.

# C.B.S. EXCHANGES (No. 1 Systems). CORD TEST CIRCUITS.

L. 801 7.1.21  
C.B.S. 226 D.

## TYPICAL CORD CIRCUITS.

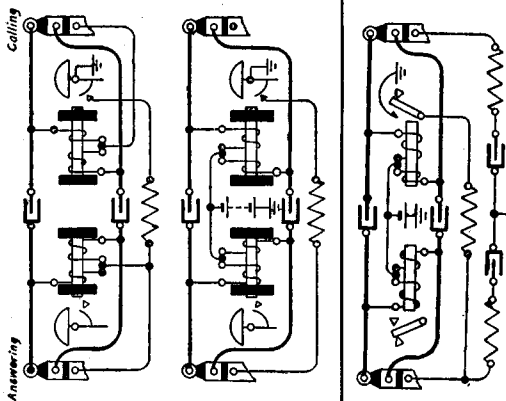

## FIG. 1. C.B.S. NON-MULTIPLE EXCHANGES.

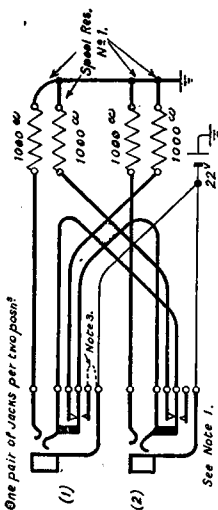

## FIG. 2. C.B.S. MULTIPLE EXCHANGES.

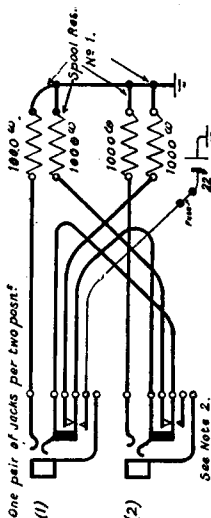

NOTE 1.—(a) Insert ansrg. plug into Jack 1, suprvy. signal should not operate. (b) Throw spkg. key and shake cord, a scraping noise should not be heard in recvr. (c) Insert calling plug into Jack 2, both signals should operate. (d) Withdraw ansrg. plug, both supvy. signals return to normal posn. (e) Shake calling cord, a scraping noise should not be heard in recvr. NOTE 2.—Repeat (a) and (b) as above. (c) Restore spkg. key, then insert calling plug into Jack 2, both signals should operate. (d) Throw spkg. key and shake callg. cord, a scraping noise should not be heard. (e) Withdraw ansrg. plug, both supvy. signals return to normal posn. NOTE 3.—Dotted conn. should be made for testing cordis wired to C.B.S. 226, Fig. 5. Shake test on junct. cord is then effected by Insertg. plug into Jack 2, and subs. plug into Jack 1

# C.B.S. No. 2. EXCHANGES. CORD TEST JACK CIRCUITS.

L. 813 5.6.25  
C.B.S. 543.

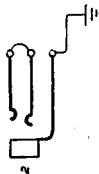
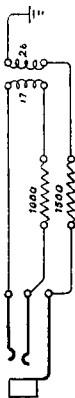

## NOTE 1.

- a. Partially insert answering plug into Jack 1, answering supervisory signal should operate.
- b. Fully insert answering plug into Jack 1, and the signal should be released.
- c. Throw listening key and shake cord, a scraping noise should not be heard in the receiver.
- d. Repeat a, b and c, using calling plug in Jack 1, for testing the calling side.

## NOTE 2.

- a. Insert answering plug in Jack 2, answering supervisory signal is operated.
- b. Partially insert calling plug in Jack 1, and the calling supervisory signal should operate.
- c. Fully insert calling plug in Jack 1, answering and calling supervisory signals should be released.

### C.B.S. No. 3 EXCHANGES. CORD TEST JACK CIRCUIT.



#### NOTES.

- a. Partially insert answering plug in the Jack—the supervisory signal should operate.
- b. Fully insert answering plug in the Jack—the signal should be released.
- c. Throw the listening key and shake the cord—a scraping noise should not be heard.
- d. Repeat a, b and c, using the calling plug in the Jack, for testing the calling side.

# TESTER No. 39 (MARK 234)

**T. 109** 25-2.22  
T.L. 945 B.

FOR TESTING SWITCHBOARD CORDS AT THE REPAIR BENCH AND FOR TESTING MULTIPLE CABLES AND JACKS ON NEW WORK (BEFORE CROSS-CONNECTING) IN EXCHANGES WHERE THE "LINE AND CUT OFF RELAYS" ARE ASSOCIATED WITH THE ANSWERING JACKS.

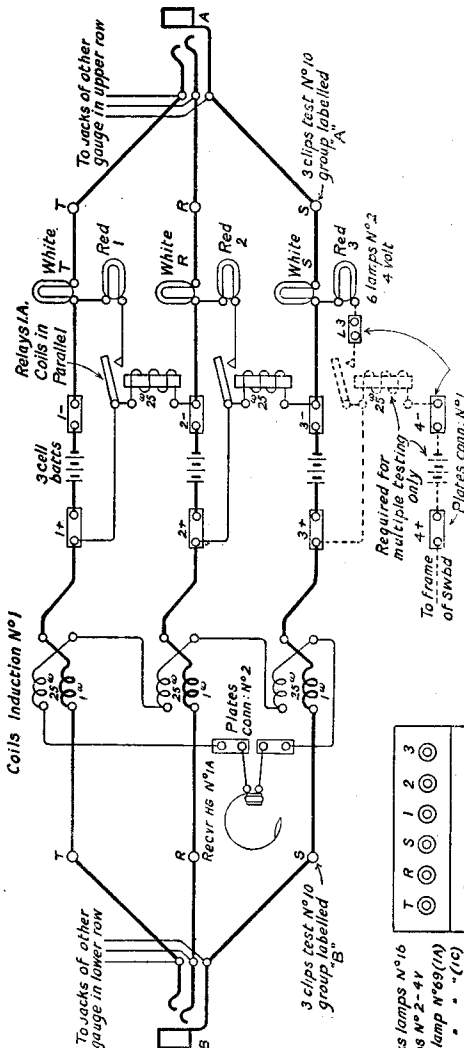

- 6 jacks lamps N°16
- 6 lamps N°2-4V
- 3 caps lamp N°69(1A)
- 3 " " " "(1B)

Jack 310 MN  
Ebonite bush  
for recvr cord

6 clips  
test N°10

T	R	S	1	2	3
⊙	⊙	⊙	⊙	⊙	⊙
A	○	○	○	○	○
B	○	○	○	○	○
A					
⊙	⊙	⊙	⊙	⊙	⊙
T	R	S	T	R	S
⊙	⊙	⊙	⊙	⊙	⊙

### FUNCTIONS OF LAMPS.

- Test for continuity or high res. on tip, ring and sleeve respectively
- Glowing shows contact or reversal on tip and ring.
- Glowing shows contact or reversal on ring and sleeve.
- Glowing shows contact on sleeve and frame of swbd.
- Glowing shows contact on ring and sleeve.
- Glowing shows contact on ring and frame of swbd.
- Glowing shows contact on tip and frame of swbd.
- No glow on Lamps T, R or S denotes disconnection.

### Lamps T, R & S

- Lamp No. 1.
- Lamp No. 2.
- Lamp No. 3.
- Lamps No. 1 & 2.
- Lamps No. 1, 2 & 3.
- Lamps No. 1, 2 & 3.

**INSTRUCTIONS.**

**T. 109**

CORD TESTING ON REPAIR BENCH.	MULTIPLE TESTING.
<p>Connect fastener end of cord to Clips B and insert plug end of cord into Jack A.</p> <p>Observe that the three White Lamps T, R and S glow with equal brilliancy except in the case of cords with steel conductors, when Lamps S will be brighter than T and R.</p> <p>For double-ended cords insert one plug into Jack B and the other into Jack A.</p> <p>The receiver H.G. No. 1 should be used and the cords shaken during tests.</p> <p>Intermittent disconnection will be indicated by a scraping noise in Receiver.</p>	<p>(a) Connect one cord to Clips A and the other to Clips B. When multiple is in position in the Switchboard make Jack to Jack test with Tester No. 39 both before and after clamping process.</p> <p>(b) Make end to end test with Tester No. 34 (Generator Test Set C.B. 1189). Plugs to be inserted in vertically adjacent Jacks in the case of all Jacks not separated by designation strips or spaces.</p> <p>(c) Make insulation test with megger (250 volts).</p> <p>(d) Make an end to end test with Tester No. 39.</p>

**TO BE REQUISITIONED SEPARATELY.**

**FOR CORD TESTING**  
 1 Receiver H.G. No. 1 A, and cord Inst. No. 232.  
 9 Cells, dry, "Y"

**FOR MULTIPLE TESTING**

1 Relay No. 1 A }  
 12 cells, dry "Y" } C.B. Nos. 1 & 10 Exchanges.  
 2 plugs, No. 309, red }  
 2 cords, switchboard, 385, green } C.B. No. 1 Exchanges.  
 2 plugs, 310 red }  
 2 cords, switchboard, 328 } C.B. No. 10 Exchanges.

==== LIST OF ====

# Technical Pamphlets for Workmen

(Continued)

---

---

**GROUP D**—*continued.*

18. Distribution Cases, M.D.F. and I.D.F.
19. Cord Repairs.
20. Superposed Circuits. Transformers. Bridging Coils and Retardation Coils.
21. Call Offices.
22. Units, Amplifying. (*Not on Sale.*)

**GROUP E.**

1. Automatic Telephony : Step-by-Step Systems.
2. Automatic Telephony : Coded Call Indicator (C.C.I.) Working.
3. Automatic Telephony : Keysending " B " positions.

**GROUP F.**

1. Subscribers' Apparatus. Common Battery System.
2. Subscribers' Apparatus, C.B.S. Part I—C.B.S. No. 1 System.
3. Subscribers' Apparatus. Magneto.
4. Private Branch Exchanges—Common Battery System.
5. Private Branch Exchange—C.B. Multiple No. 9.
6. Private Branch Exchanges—Magneto.
7. House Telephone Systems.
8. Wiring of Subscribers' Premises.

**GROUP G.**

1. Maintenance of Secondary Cells.
2. Power Plant for Telegraph and Telephone Purposes.
3. Maintenance of Power Plant for Telegraph and Telephone Purposes.
4. Telegraph Battery Power Distribution Boards.

**GROUP H.**

1. Open Line Construction, Part I.
2. Open Line Construction, Part II.
3. Open Line Maintenance.
4. Underground Construction, Part I—Conduits.
5. Underground Construction, Part II—Cables.
6. Underground Maintenance.
7. Cable Balancing.
8. Power Circuit Guarding.
9. Electrolytic Action on Cable Sheaths, etc.
10. Constants of Conductors used for Telegraph and Telephone Purposes.

**GROUP I.**

1. Submarine Cables.

**GROUP K.**

1. Electric Lighting.
2. Lifts.
3. Heating Systems.
4. Pneumatic Tube Systems.
5. Gas and Petrol Engines.

