

Crown Copyright Reserved

Post Office Engineering Department

TECHNICAL PAMPHLETS FOR WORKMEN

Subject :

Elementary Principles of Telegraphy and Systems up to Morse Duplex

ENGINEER-IN-CHIEF'S OFFICE.

1919.

Revised and reissued March 1924

(Reprinted Nov. 1929, including Correction Slips to date)

(" March. 1933, " " ")

(" Nov. 1934, with minor amendments)

(" Nov. 1935, including Correction Slips to date)

LONDON

PRINTED AND PUBLISHED BY HIS MAJESTY'S STATIONERY OFFICE

To be purchased directly from H.M. STATIONERY OFFICE at the following addresses :

Adastral House, Kingsway, London, W.C.2; 120, George Street Edinburgh 2

York Street, Manchester 1; St. Andrew's Crescent, Cardiff;

80 Chichester Street, Belfast;

or through any Bookseller

1938

Price 6d. Net

LIST OF Technical Pamphlets for Workmen.

GROUP A.

1. Magnetism and Electricity.
2. Primary Batteries.
3. Technical Terms.
4. Test Boards.
5. Protective Fittings.
6. Measuring and Testing Instruments.
7. Sensitivity of Apparatus.
8. Standard List of Terms and Definitions used in Telegraphy and Telephony. (*Not on Sale*)
9. Standard Graphical Symbols for Telegraphy, Telephony and Radio Communication. (*not on sale*)

GROUP B.

1. Elementary Principles of Telegraphy and Systems up to Morse Duplex.
2. Telegraph Concentrators.
3. Wheatstone System. Morse Keyboard Perforators.
4. Quadruplex, Quadruplex Repeated Circuits and Telegraph Repeaters, Simplex and Duplex.
5. Hughes Type-printing Telegraph.
6. Baudot Multiplex Type-printing System.
7. Western Electric Duplex Multiplex. Murray Duplex Multiplex. Siemens and Halske Automatic Type-printing System.
8. Fire Alarm Systems.

GROUP C.

1. Wireless Transmission and Reception.
2. Interference with Reception of Broadcasting.

GROUP D.

1. Elementary Principles of Telephony.
2. Telephone Transmission. "Loading." Telephone Repeaters and Thermionic Valves.
3. Principles of Telephone Exchange Signalling.
4. Magneto Exchanges - Non-Multiple Type.
5. Magneto Exchanges-Multiple Type.
6. C.B.S. No. 1 Exchanges-Non-Multiple Type.
7. C.B.S. Exchanges-Multiple Type.
8. C.B. Exchanges-No. 9 Type.
9. C.B. Exchanges-No. 10 Type.
10. C.B. Exchanges-No. 12 Type.
11. C.B. Exchanges-22 Volts.
12. C.B. Exchanges-40 Volts.
13. Trunk Telephone Exchanges.
14. Maintenance of Manual Telephone Exchanges.
15. Telephone Testing Equipment.
16. Routine Testing for Manual Telephone Exchanges.
17. Internal Cabling and Wiring.

[Continued on page iii of Cover.]

**Elementary Principle of Telegraphy
and Systems up to
Morse Duplex
(B.4).**

*The following pamphlets in this series are of kindred
interest:*

- A.1. Magnetism and Electricity
- B.2. Telegraph Concentrators
- B.3. Wheatstone
- B.4. Quadruplex
- B.5. Hughes Type-Printing Telegraph
- B.6. Maudot Multiplex
- B.7. Western Electric Multiplex
- C.1. Wireless Transmission and Reception

CORRECTION SLIP TABLE

The month and year of issue is printed at the end of each amendment in the Correction Slips, and the number of the slip in which any particular amendment is issued can, therefore, be traced from the date. In the case of short corrections made in manuscript, the date of issue of the slip should be noted against the correction.

The Summary portions of the Correction Slips should be completed and affixed below in numerical order.

CORRECTION SLIP TABLE - (contd.)

The month and year of issue is printed at the end of each amendment in the Correction Slips, and the number of the slip in which any particular amendment is issued can, therefore, be traced from the date. In the case of short corrections made in manuscript, the date of issue of the slip should be noted against the correction.

The Summary portions of the Correction Slips should be completed and affixed below in numerical order.

Elementary Principles of Telegraphy and Systems up to Morse Duplex

TABLE OF CONTENTS.

	PAGE
INTRODUCTION... ..	4
ELECTRIC BELL	5
SINGLE NEEDLE	6
RELAYS	9
THE DOUBLE PLATE SOUNDER	14
THE DIRECT SOUNDER	14
SINGLE CURRENT SOUNDER	16
THE POLARIZED SOUNDER	16
THE DOUBLE CURRENT SYSTEM	17
DUPLEX WORKING	19
RHEOSTAT AND DIFFERENTIAL GALVANOMETER	22
DOUBLE CURRENT DUPLEX	23
THE BRIDGE DUPLEX	21
UNIVERSAL BATTERY SYSTEM	26
CENTRAL BATTERY TELEGRAPHS	30
THE WHEATSTONE ABC	32

THE ELEMENTARY PRINCIPLES OF TELEGRAPHY

INTRODUCTION

A wire carrying an electric current has a magnetic field around it, i.e., there are lines of force in concentric circles round the wire. (Fig. 1.) This magnetic field will deflect a compass needle and the direction of the field depends on the direction of the current. If the wire be placed above a magnetic needle lying in the magnetic meridian, i.e., lying in the line of the North

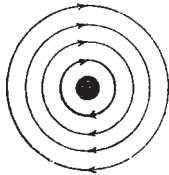

LINE OF FORCE ROUND CURRENT-CONVEYING WIRE. DIRECTION OF CURRENT DOWNWARDS THROUGH THE PLANE OF THE PAPER.

Fig. 1.

and South magnetic poles, a current flowing south to north over the needle will deflect the north-seeking pole to the west. This is readily remembered by the fact that the first letters of the essential words spell SNOW. But the better rule is as follows :- Place the right hand (palm downwards) between the wire

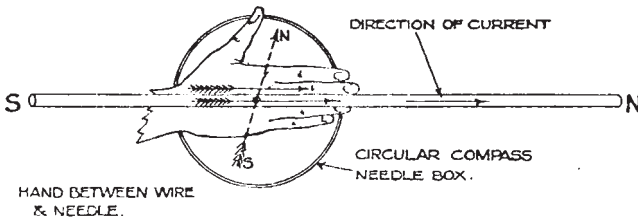

Fig. 2.

and the needle. If the current be flowing from the wrist to the fingers, the outstretched thumb will indicate the direction in which the north-seeking pole of the needle will be deflected (Fig. 2).

By arranging a number of turns of wire in the form of a coil, technically termed a solenoid (Fig. 3), a stronger magnetic field can be obtained. The strength of the field depends on two things—the number of turns of wire and the current flowing. Iron conducts lines of force far better than air, and the introduction of an iron core enormously increases the magnetic field. The softer the iron the greater is its effect.

Fig. 4 illustrates one form of electro-magnet.

The two limbs are united at their base by the soft iron yoke, and the armature of similar material is placed above. The path of the lines of force, termed the magnetic circuit, is shown by the dotted line. In order to obtain opposite polarity on the two poles of the electro-magnet the windings are reversed on the two limbs.

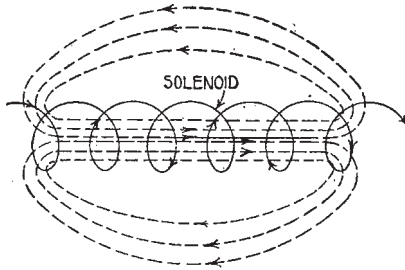

Fig. 3.

The effect of the current is to cause the armature to be attracted; and here it may be said that in any electro-magnetic arrangement there is always a tendency for the armature to move in such a way as to shorten the lines of force as though, indeed, a tension or pull existed along their length. When an electro-magnet is carrying sufficient current to perform its function of attracting its armature, it is said to be energized. One of the simplest forms

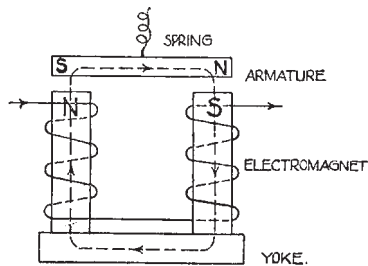

Fig. 4.

of signalling device consists of an electric bell, battery and press button. By arranging that certain rings shall have definite meanings, simple messages may be transmitted. This arrangement is termed a code of signals, and is adequate for indicating, for example, that a carrier has been placed in a pneumatic tube, that a carrier has been received, that empty carriers are required, or similar messages. The electric bell (Fig. 5) consists of an electro-magnet

with a soft iron armature A, carried by a flexible spring. At 13 the points of contact are tipped with non-oxidable metal. Immediately the press button is depressed, the circuit of the battery is completed through the electro-magnet and the armature is attracted. In moving forward the hammer strikes the bell gong, and at the same time breaks the continuity of the circuit at B. This allows the armature to fly back under the influence of the spring and the circuit is again completed at B. The armature is again attracted and released, this process continuing so long as the press button is depressed. By the addition of a pin on the armature A it is possible to arrange that a pivoted disc will

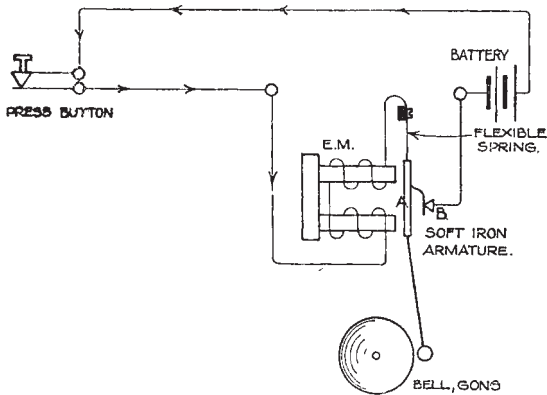

Fig. 5.

fall when the bell is operated. This provision is sometimes required in order that an indication may be given that the bell has been operated when there is no one in the room to observe it.

SINGLE NEEDLE

The single needle instrument consists essentially of two parts ; the dial on which the signals are received and the commutator or key part on which the message is signalled. The signals are formed by the deflections of the needle to the left or to the right in various combinations. The alphabet employed is that of the Morse code, a deflection to the left corresponding to a dot and a deflection to the right to a dash. The whole of the letters of the alphabet are signalled by one, two, three or four movements in the needle.

The Commutator or sending device when at rest completes the circuit of the coils to the line, whilst the depression of a key puts the battery in circuit in a direction which depends upon whether the left or the right key is depressed. The Dial consists of a special form of galvanometer. Within a pair of coils of wire is placed a magnetic needle, which deflects to the left or to the right according to the direction of the current through the coils. The actual direction in which the needle deflects is in the direction to which the current passes from terminal to terminal, i.e., if the current passes through from left to right the top of the needle is deflected to the right-hand side, and this applies to all galvanometers used by the Post Office.

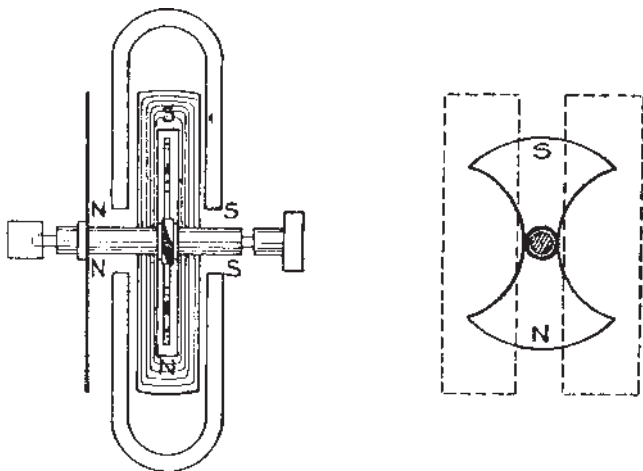

Fig. 6.

The magnetic needle is made of soft iron and consists, magnetically, of two parts separated from each other by a layer of spelter (non-magnetic). The needle is magnetized by two large horseshoe magnets, placed over the ends of the axle, which impart the polarity indicated in Fig. 6. If the permanent magnets were omitted and a small piece of magnetized steel were used for the needle it would soon become demagnetized by the passage of the working currents through the coils. During lightning storms, when comparatively large currents may find their way through the apparatus, demagnetization of the needle would be quite certain. This, then, explains why it is necessary to employ the two large horseshoe magnets to maintain the magnetism of the needle. The coils have a resistance of 200 ohms, i.e., 100 ohms each, and satisfactory signals can be obtained with a current of as little as 3 milliamperes.

The commutator used in practice is of a somewhat complicated character. It is provided with 6 terminals, two of which (Z) and (C), are used for connecting up the battery to the keys, two others (A) and (B) from which the signals are sent out. The function of the two terminals (X) and (Y) at the back of the key will be appreciated when the double-plate sounder apparatus is

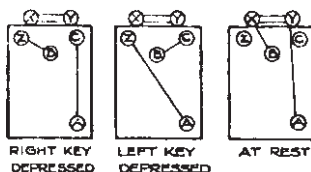

Fig. 7.

considered. The connections formed in the various positions of the keys are indicated in Fig. 7. The connections of a 3-station circuit are indicated in Fig. 8. It will be observed that the signals sent out from any station are also indicated on the sender's dial.

Earth Return - In Fig. 8 it will be observed that the circuit between the two terminal stations is completed via the earth. The resistance of a good earth connection should not exceed 10 ohms, and in the case of large offices it is often only a fraction of an ohm. A good earth connection may usually be

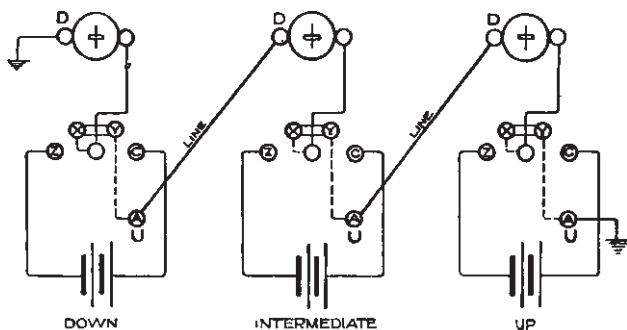

Fig. 8.

obtained by connection to water-pipes, or by sinking a small earth-plate buried, preferably, in moist ground. It is particularly important that earth connections should not be made to gas-pipes, since, during lightning disturbances,

large currents may flow with resulting fire risks. The earth return dispenses with a second or return wire, and the resistance which would thereby be introduced.

In the case of a large telegraph office a number of circuits may send out currents in both directions to the same station. If, for the sake of argument, there are at a given moment 30 circuits each sending out 20 milliamperes from Liverpool to Manchester, and 20 circuits each sending 20 milliamperes over other lines in the opposite direction, the current from 20 circuits in each direction will balance each other, and only the current represented by 10 such circuits will actually go through the earth between these offices. In the event of a defective earth connection, i.e., an earth connection of high resistance, the signals sent on one circuit will be received on other circuits, especially those of low resistance, which are connected to this earth plate, the current flowing through such circuits being produced by the difference of potential across the earth connection.

Up and Down Stations.- In order that the internal connections of each type of apparatus may always be the same the connection of the set as a whole to **line** or **earth** differs at the ends of the circuit. One end is termed the "Up" Station, and the other is called the "Down" Station. The station nearest to London is "Up" and that furthest removed from London is "Down," i.e., London is the "Up" station on every London circuit. In the case of a Manchester-Newcastle circuit, Manchester is "Up" and Newcastle "Down". Stations introduced between the "Up" and "Down" stations are termed "Intermediate" stations. The following rules govern the connection of the apparatus as a whole :-

1. **"Up" Station.** - "Up" line terminal connected to earth, "Down" line terminal connected to the "Down" line.
2. **"Down" Station.** - "Down" line terminal connected to earth, "Up" line terminal to the "Up" line.
3. **"Intermediate" Station.** - "Up" line terminal to the "Up" line and "Down" line terminal to the "Down" line. The advantage of the single needle system consists in its simplicity. It is also easier and quicker to learn to operate than a sounder. The reading of the signals by the eye is a somewhat trying process, and two sounding pieces usually replace the ivory stop pins. These sounding pieces emit different notes when struck by the needle, and so enable the instrument to be read by sound.

RELAYS

A relay may be defined as an instrument which as the result of a current passing through its coils makes or breaks electrical connections. The relay is termed a polarized relay when the direction in which its tongue moves de-

depends upon the direction of the current through its coils. A non-polarized relay is operated by a current passing through its coils in either direction. Generally speaking, polarized relays are more sensitive than **non-polarized** relays, and usually the armatures of nonpolarized relays are unmagnetized soft iron, whilst those of polarized relays are either permanent or induced magnets.

The object of a relay is generally to save battery power and to increase speed of working. A comparatively small current is sent over a line to direct the movement of the tongue of the relay, the actual current through the receiving apparatus being furnished by a special battery, termed in this connection a **local battery**.

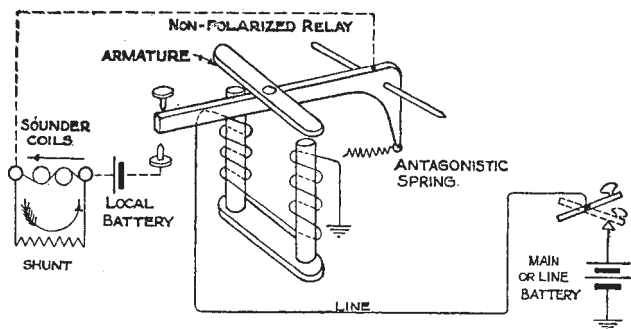

Fig. 9.

An electro-magnet with a light armature furnished with contacts constitutes a non-polarized relay (Fig. 9). The depression of the Key sends out a current which passes over the line and pulls down the armature of the relay. This completes the local circuit and the sounder is actuated by the local battery.

The purpose of the high resistance coil or shunt joined across the coils of the sounder is to prevent sparking at the contacts of the relay when the local circuit is broken by the release of the armature of the relay. The magnetic field of a sounder (see Fig. 3) collapses when the current in its coils is stopped, and in doing so cuts the windings of the coils, with the result that an E.M.F. is generated in the same direction as the current which energized the sounder. This E.M.F., known as the E.M.F. of self-induction, joins with and adds to the E.M.F. of the local battery, with the result that a spark occurs at the moment of breaking the contact. This sparking is obviated by the non-inductive

shunt (i.e., a resistance coil possessing little or no self-induction). The current due to the inductance of the coils circulates round the resistance coil, and thus the difference of potential between the contact points is reduced to a very small and harmless value.

The contact points of relays are tipped with platinum because this metal does not oxidize in air, and, being very hard, it withstands the continual knocks which operation of the relay involves.

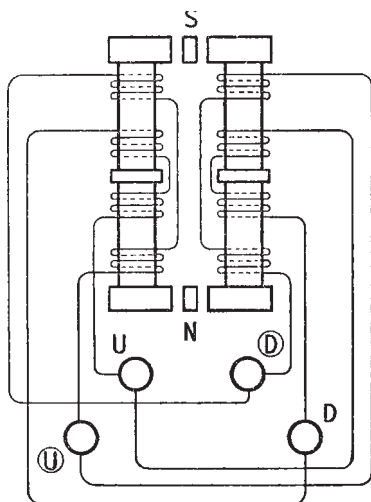

The arrangement of the terminals is as seen from below the Relay base.

Fig. 10.

A Post Office Standard relay consists of two electromagnets placed side by side, with two soft iron armatures between the pole pieces. These armatures are magnetised (i.e., are polarized) by means of a curved horse-shoe magnet the poles of which are situated behind them as indicated in Fig. 10A. The method of winding the electro-magnet is shown in Fig. 10. The armature axle also carries a tongue piece, to the front extremity of which a platinum contact is secured. The amount of movement of the tongue is limited by two adjustable platinum-tipped contact screws. The passage of a current through the coils in the marking direction makes the top of the left-hand electro-magnet of south polarity,

and the top of the right-hand electro-magnet of north polarity, the result being that the armature moves over to the right. The lower armature is, of course, subjected to similar forces. Reversal of the current reverses the direction in which the armature tends to move.

The relay is differentially wound, i.e., it has two sets of windings having (i) equal resistance and (ii) equal effects on the cores of the relay when carrying equal currents. The two coils, the terminals of which are marked D, U and (D) and (U) each have a resistance of 100Ω ; the effect of a current of, say, 10

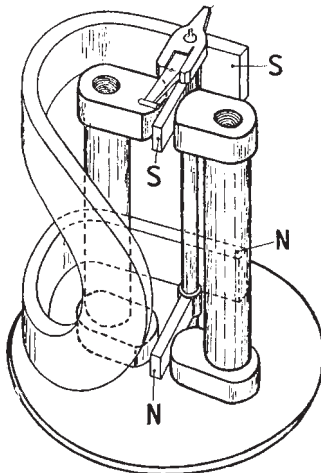

Fig. 10A.

m.a. passing from D to U should be balanced by a current of 10 m.a. passing from (U) to (D). The fields due to the currents oppose each other with the result that the cores of the relay are not magnetized. The differential condition of a relay can readily be proved by making two successive tests. The first test, for equal magnetization, is made by joining together terminals U and (U) and sending a positive current of 20 m.a. through the coils from terminal D to terminal (D). With the relay tongue adjusted to its most sensitive condition, i.e., neutral, the tongue having been placed on the M contact should be unaffected by the passage of the current. The second test, for equal resistance of

the electro-magnet coils is made by connecting terminals U and (D) and also terminals (U) and D. A dry cell is joined between U and (U) With the tongue adjusted as before it should remain on whichever contact it is placed while the current is applied.

For working purposes the coils may be joined in parallel by connecting (U) to U and (D) to D, or in series by joining U and (D). In parallel the resistance of the arrangement is half that of one coil (50Ω), and in series twice that of one coil (200Ω). To produce equal effects twice as much current is required if the coils are joined in parallel as would be needed if they were joined in series. If each coil consisted of 10 turns of wire, and a current of 10 m.a. is passed through the instrument joined in the series, there are 10 m.a. in each coil. In order to produce this condition with coils joined in parallel, a current of 20 m.a. would have to be supplied, which would divide equally between the two windings, thus producing the same condition as in series, viz., 10 m.a. in each coil.

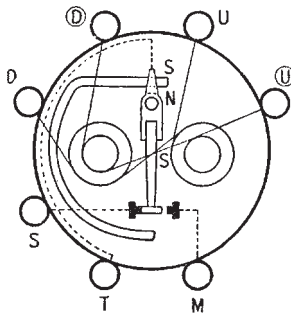

Fig. 11.

As relays are now only required to be joined in parallel for special cases the 7 terminal type is being superseded by a 6 terminal type. In this case the test for equal magnetization cannot be made as the coil ends, formerly terminated on U (D) terminals, are connected to a common terminal. Relays of the 6 terminal type have a rectangular base and contact plates are carried out from the terminals.

A current passing from D to U or (D) to (U) causes the armature to be held over to the left, whilst a current in the opposite direction sends the armature to the right. The position of the terminals is indicated in Fig. 11. The tongue of the relay described rests either upon S or upon AI contact. Unless

faulty, it cannot remain in a central position. The two contact screws are mounted upon a platform the position of which is regulated by a milled screw at the base of the relay. The distance between the armatures and the pole-pieces can therefore be varied at will by adjusting the screw.

The adjustments of the relay are (i) for play of the tongue between the contact points ; the smaller the play the more rapid is the relay in action, and (ii) for "bias". A relay is said to be adjusted to "neutral" condition when the tongue will remain on either S or M indifferently. It has a spacing bias if, after deflection with the finger to M, it flies back to S immediately the finger is removed. Similarly it has a marking bias if the tongue flies back to M after deflection to S.

THE DOUBLE PLATE SOUNDER

In large or noisy telegraph offices the volume of sound obtainable from the single-needle instrument provided with sounding pieces is insufficient, and this led to the introduction of the Double Plate Sounder. The set consists of a single-needle commutator, main battery, a relay, a local battery for operating the two plate sounders, and a galvanometer which is placed in the line circuit. The signals sent out do not affect the apparatus used for receiving the messages, the relay being connected between the terminals x and y of the commutator; this relay is, however, of the "neutral" pattern. It is a P.O. standard relay of the type previously described, but furnished with two very light and adjustable spiral springs placed at right angles to, and attached to the tongue of the relay. These springs hold the tongue midway between the S and M contacts which are used to join the local battery to the left and right plate sounders respectively. The plate sounder consists of an electro-magnet with an armature which, when depressed, causes a small hammer to strike a brass or steel sounding plate.

The Double Plate Sounder is dying out, its place being taken either by telephones or, on the busier circuits, by sounders.

THE DIRECT SOUNDER

In skilled hands the sounder is as rapid in operation as the single needle or double plate sounder, and moreover it lends itself to duplex and quadruplex working. The simplest form of sounder circuit consists of a single current key, battery, and sounder, suitably joined up. The Post Office pattern of sounder consists of an electro-magnet with a soft iron armature held away from the coils by an adjustable spring. Provision is made by means of a screw to determine the distance between the coils of the electromagnet and the armature

when the latter is down. The function of the upper screw is to regulate the play of the armature and incidentally to vary the volume of the sound produced. The 20Ω sounder requires a working current of approximately 100 m.a. and the 900Ω sounder about 26 m.a.

Single Current Key.- The single current key consists of a pivoted brass lever playing between front and back contacts. These contacts are formed of a bold-silver alloy (10 per cent. bold, 90 per cent. silver).

Single Coil Galvanometer. - This instrument is similar in general form to the single-needle dial. Its coils are, however, wound to resistance of 30Ω shunted with 1000Ω . The old form is provided with ivory stop pins, a current of 9.3 m.a. being required to produce a deflection to either stop pin. The later pattern instrument has an engraved dial.

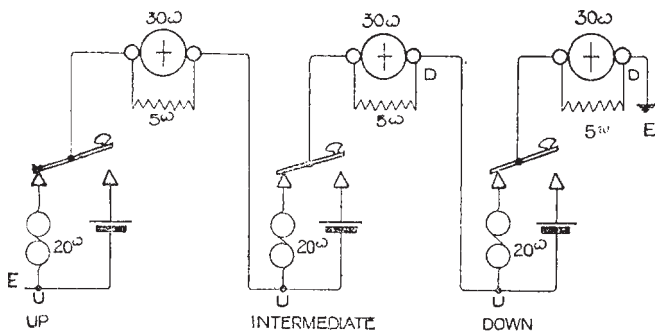

Fig. 12.

Connections. - Three direct sounder stations are shown in Fig. 12. The 5Ω shunt is external to the Galvanometer and is provided to prevent the heavy current required to operate the sounders from damaging the Galvanometer needle. The remarks made with regard to the connection of single needles between up and down lines apply equally to the direct sounder. Circuits of this character were at one time used between Head Post Offices and sub-offices within a very short distance of the Post Office.

Direct Writer. - This instrument consists of an electromagnet with an armature which, when actuated, causes a revolving disc, immersed in an ink-well, to be brought into contact with a paper tape moved at a uniform speed above it by a spring-driven train of wheels.

SINGLE-CURRENT SOUNDER

In this set of apparatus a relay is employed. The advantages gained as compared with the direct sounder are:

- (i) economy of battery power.
- (ii) the volume of the signals is independent of the value of the current received and the relay permits a larger variation in the received current before working is rendered impossible.
- (iii) the combination of relay and sounder enables adjustments of the relay to meet line conditions, and the sounder adjustments necessary to meet operating requirements to be made independently.

The connections are shown in Fig. 13. The relay is given a definite spacing bias sufficient to return the tongue smartly to spacing upon cessation of the current ; but it should not be sufficient to cause clipping of the signals. When the key is released the spacing bias reasserts itself and returns the tongue to the spacing side, thus ending the signal.

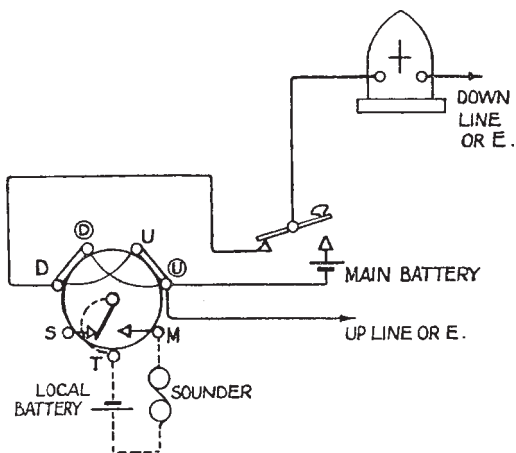

Fig. 13.

THE POLARIZED SOUNDER

The Polarized sounder is similar in form to the ordinary sounder previously described. The yoke of the electro-magnets is, however, replaced by a permanent horse-shoe magnet, a clearance of 5 mils of non-magnetic material being interposed between the magnet and the cores. The effect of this

magnet (Fig. 14) is to polarize the cores. When the instrument is properly adjusted the upper and lower positions of the armature are positions of balance which the smallest impulse upsets, thus starting movement of the armature. In the upper position the pull of the spring prevails, whilst in the lower position the magnetic attraction is greater than the pull of the spring. In the standard form of polarized sounder all the adjustments, with the exception of the spring, have been fixed.

The polarized sounder is wound to various resistances, e.g., $100\Omega + 100\Omega$, $200\Omega + 200\Omega$, $500\Omega + 500\Omega$, 2000Ω and $4,500\Omega$. The polarized sounder D. $500\Omega + 500\Omega$ can be actuated with a current of as little as half a m.a. whilst

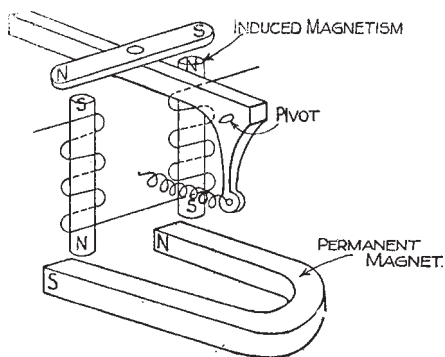

Fig. 14.

with 10 m.a. good working signals are obtainable, and it has been found that the received current may be varied between 3 m.a. and 40 m.a. without affecting the reception. This type of sounder is differentially wound and is employed in place of a relay and local sounder on short underground circuits where the conditions are suitable.

THE DOUBLE-CURRENT SYSTEM

In the single-current system the tongue of the relay is restored to the normal condition upon cessation of the signalling current, either by magnetic bias or by a spring in the case of a non-polarized instrument. In the double-current system the intervals between the marking currents are filled by a spacing current. The spacing current takes the place of a magnetic bias on a relay. The result is that the relay may be adjusted to neutrality, and the marking current therefore has no fixed spacing bias to overcome.

This gives greater flexibility in adjustment and provides for the different values of current sent out by the various stations on the circuit according to the condition of their batteries. In the case of long lines the use of the double-current system gives a higher speed of working, but this is of course only of importance when the circuit is worked by automatic or other fast speed apparatus. A telegraph line possesses, besides resistance, a certain amount of capacity, the effect of which is to slow down the rate at which the current rises and falls and to distort the signals. The advantages of the double-current system may be summarized as follows :

1. The discharge of the line is hastened.
2. The relay is worked in its most sensitive condition, i.e., neutral.

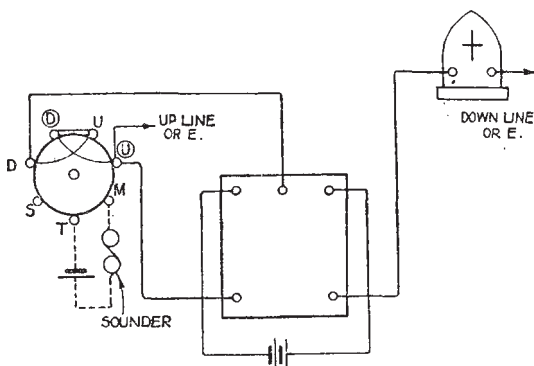

Fig. 15.

3. The effects of residual magnetism in the cores of the receiving relay are reduced.
4. The effects of a variation of received current are reduced, since both marking and spacing current are equally affected and the instrument is therefore self-adjusting.

The connections of a double-current set, shown in Fig. 15, call for little comment. The up and down line terminals are distinctly marked and are joined by up and down lines as previously indicated (see page 9).

The double-current key (Fig. 16) is provided with a switch which joins up the relay for the reception of signals when at "receive", and when turned to "send" connects the battery between the up and down line terminals in a direction dependent upon whether the key is at rest (spacing current) or de-

pressed (marking current). The key consists of a divided lever playing between four contact springs. A section through the end of the key is illustrated in Fig. 16 and beneath it are shown the connections made by the key in its various positions.

A sufficient number of Leclanché WK2 cells to furnish a current of 14 to 17 m.a. are joined in series to form the line battery; the local battery consists of 3 cells WK2. With a polarized sounder a current of 10 m.a. will suffice, but it should not, however, be overlooked that the resistance of the relay is only 200Ω , whilst that of the polarized sounder is $1,000\Omega$.

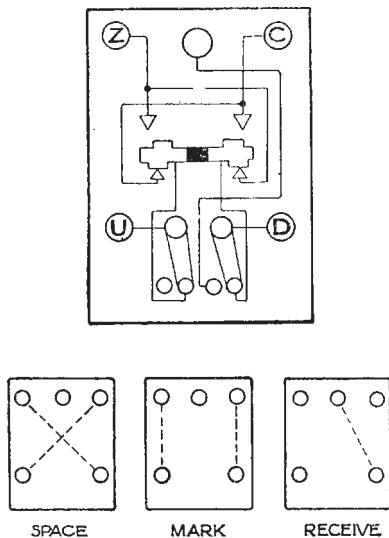

Fig. 16.

DUPLEX WORKING

Duplex working provides that on a single wire signals may be sent from each end at the same time without interfering with each other. This result may be obtained in several ways:

1. By the differential method.
2. By the bridge method.
3. By combination of bridge and differential as in one form of C.B. duplex.

The differential method is the one most generally adopted; the bridge method being used only on long cable circuits. If two direct sounder stations

on one wire attempted to signal together both sets of signals would be cut out. When only one key was depressed at a time the mark would be received at the other end; but, when both keys were depressed simultaneously, both sounders would be cut out of circuit at the back stop of each key and no signals would be formed. In order to obtain duplex working it is necessary to arrange that when both keys are depressed both sounders are actuated. If this condition can be secured, then the marks will be made by the current sent out when only one key is depressed and by the special arrangement when both keys are depressed. In this way both stations may signal simultaneously without mutual interference. This condition is readily obtained with the aid of differentially wound apparatus; and in Fig. 17 the requisite connections are indi-

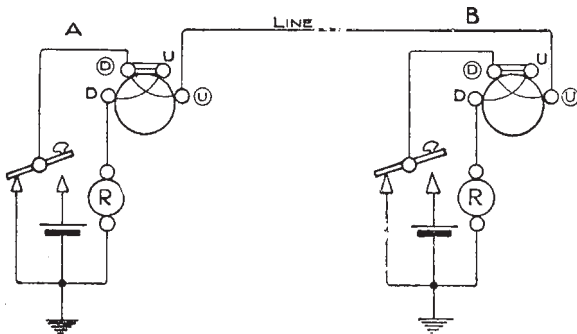

Fig. 17.

cated. The current sent out by the key divides into two equal parts, each of which passes through a different coil of the sending station relay. These two currents pass through the coils of the relay in opposite directions, thus producing no effect whatever upon the relay at the sending station. One half of the current passes to line through the receiving relay at the distant end and thus makes a signal. When both keys are depressed the two batteries have similar poles connected to line. This prevents any current from flowing along the line and leaves the current flowing in the other or compensation circuit coil of the relay free to produce a signal. When only one key is depressed the signal is made by the current received from the sending station; but when both keys are down each relay operates with the current from its own battery owing to the stoppage of the line current.

The connections of such a circuit are indicated in Fig. 17. The single-current key when at rest earths the split of the relay, and when depressed joins up an earthed battery. One coil of the relay is connected to line and the other to a rheostat. The resistance in the rheostat is adjusted until it equals the resistance of the line plus that of the distant apparatus. When this point is reached the current sent out divides equally between the two coils of the relay. The arrangements are identical at each end.

1. With the keys at rest both relays remain in the rest position due to the spacing bias.

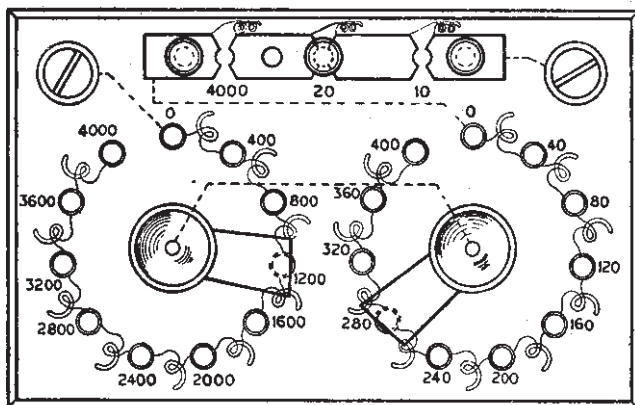

Fig. 18.

2. When station A depresses his key a current of, say, 20 m.a. flows to the split of the relay, 10 m.a. passing through the plain coil and rheostat to earth and 10 m.a. through the circle coil, line, circle coil of the B station in the direction U to D to earth and back to the battery. Station A's apparatus is unaffected, whilst a mark is recorded at Station B.
3. When B depresses his key the current divides equally between the coils in his relay and the half of the current passing out to line, passes through the circle coil of the A station relay and produces a mark.
4. When both keys are depressed the path of the current via the line is stopped, and both relays mark as a result of the current furnished by their own batteries.
5. The only other condition to be considered is when one key is depressed and the other one occupies momentarily a position midway between

the rest and the down positions. In this case the received current via the line passes through both coils of the relay in series at the station where the key occupies an intermediate position and the mark is uninterrupted.

Rheostat and Differential Galvanometer - A telegraph line varies in conductor resistance and insulation resistance owing to changes of atmospheric conditions, and therefore the balancing resistance must be capable of variation. This necessitates the use of a rheostat (Fig. 18). It consists of ten 40Ω and ten 400Ω resistance coils joined between the brass studs and brought into circuit according to the position of the phosphor-bronze radial arms. In addition, three coils, 10Ω , 20Ω , and $4,000\Omega$ are provided and are introduced by removal of the respective plugs. In Fig. 18 a resistance of $5,490\Omega$ is introduced between the terminals of the rheostat. Any value from 10Ω to $8,430\Omega$ by steps of 10Ω is obtainable.

All resistance coils are wound so as to have as little self-induction as possible. This is effected by taking the length of wire for the required resistance, forming it into a loop with free ends and then winding the doubled wire into a coil. The magnetic field which each wire of the loop tends to generate is equal and opposite to its companion, therefore no magnetic field is produced and there is consequently no self induction.

The **differential galvanometer** is similar in form to the S.C. galvanometer, save that it is provided with two coils differentially wound to a resistance of 50Ω each, and the dial has a scale of degrees, and the stop pins are omitted. Each of the 50Ω coils is shunted by a plain or non-inductive resistance of 300Ω in order to reduce the inductance of the galvanometer for high-speed at Wheatstone working; the effective resistance of each of the coils being thus 43Ω . A deflection of 20 deg. is produced by a current of 8 m.a. through one coil and 30 deg. by 11 m.a. The remarks on the differential winding of a relay apply equally to the differential galvanometer, e.g., the current required to produce a deflection of 20 deg. through both coils in series is 4 m.a. and the resistance of the galvanometer is then 86Ω against $21\frac{1}{2}\Omega$ when the coils are in parallel. The differential condition of the instrument may be verified as described in the case of a relay. In ordinary duplex working the two lower terminals are strapped, thus dividing the current between the two coils, one of which is in the line circuit and the other in the compensation circuit, the arrangement corresponding to the strapped terminals of a relay. The term, "double split", is sometimes used to indicate the connections obtaining in duplex working when the set has a separate main battery, as in Fig. 19.

DOUBLE CURRENT DUPLEX

The skeleton connections required for double-current duplex working are indicated in Fig. 19. The double-current key which determines the direction of the current is joined between the strapped terminals of the differential galvanometer and the relay, whilst the compensation circuit contains an amount of resistance equal to the resistance of the line, one coil of the distant galvanometer (43Ω), and one coil of the relay (100Ω). With the keys at rest the two batteries combine in the line circuit, thus producing a current twice as great as that in the compensation circuit. This preponderance of current causes the tongues of both relays to be held to the spacing side. Similarly, when both keys are depressed, the current is every where reversed in direc-

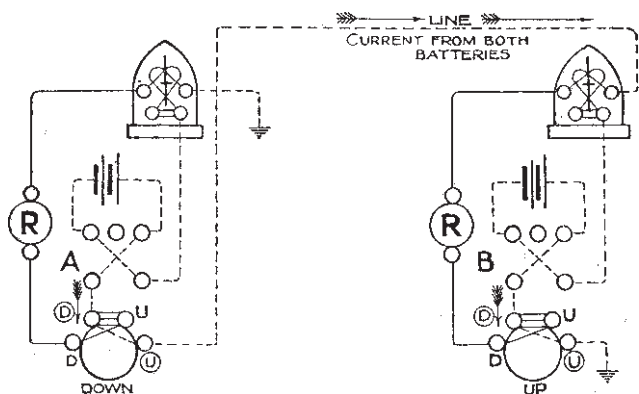

Fig. 19.

tion. The preponderating current in the line circuit therefore causes each relay to mark. There now remains the condition in which one key is depressed and one is at rest. In this condition (Fig. 20) the batteries oppose in the line circuits and both station's compensation circuits are left free to produce their effects, which at the station where the key is depressed consists of a spacing effect and the station where the key is at rest of a marking effect.

Here it may be well to explain that the compensation circuit must resemble the line circuit both in resistance and in capacity. The capacity of a line is, however, distributed along its length, and therefore 1, 2 or 3 condensers with timing resistances may be required to balance it.

Connections. - In order that the circuit may be worked simplex during slack periods and thus save current a switch is provided which changes the

connections indicated in Fig. 19 to those of Fig. 15. This "6-terminal-2-position switch" consists of 6 segments which are joined together by two U-shaped

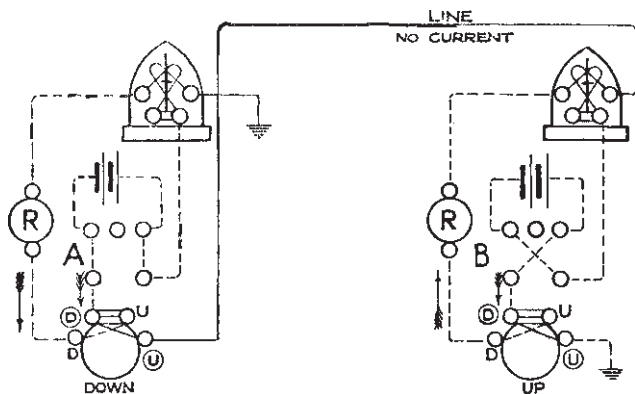

Fig. 20.

brass springs insulated from each other. In this way the equivalent of two 2-way switches operated by a single lever is obtained. The top three terminals

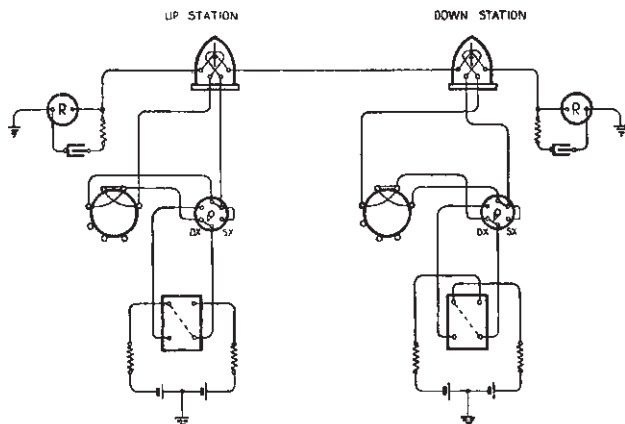

Fig. 20A.

of the switch deal with the D terminal of the relay, rheostat and receiving terminal of the D.C. key, whilst the bottom set of three terminals deals with the left-hand lower terminal of the D.C. key, the split of the relay and U-circle

of the relay. The connections may readily be memorized by the mnemonic "DRULSK". D refers to D of the relay, R = Rheostat, U = (U) of relay, L = Left of Key, S = Split of relay, K = receiving terminal of Key. The arrangements in use where offices are provided with common secondary batteries are shown in Fig. 20A.

THE BRIDGE DUPLEX

Whereas the differential duplex depends on current balances, the bridge duplex depends upon a balance of potentials. Fig. 21 may be compared with Fig. 19 to illustrate the difference in arrangement. The compensation circuit contains resistance equal to that of the line and distant apparatus, as in the differential

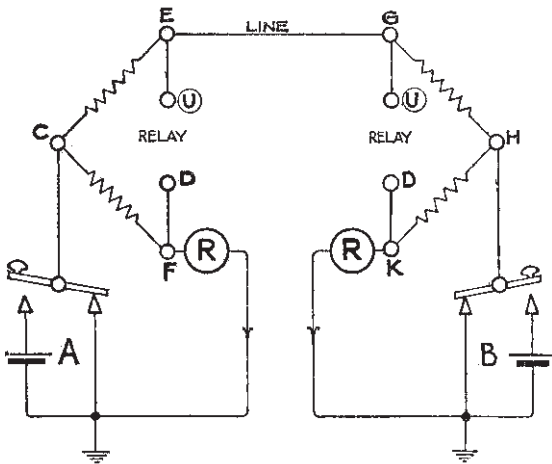

Fig. 21.

duplex, but the current divides between two equal resistances termed the duplex resistance coils CE and CF at A, and between HG and HK at B. The relay is joined across the ends of these duplex resistance coils. When the key at A is depressed the points E and F are raised to equal potentials, and consequently no current flows through the relay at A, which is unaffected. Similarly the depression of the key at B, when the key at A is at rest, produces no effect on the relay at B. When one key only is depressed the distant relay marks by the current which passes through the relay in series with the lower duplex resistance coil and rheostat in parallel but with this path shunted across the upper duplex coil.

When both keys are depressed similar poles are opposed in the line, and the relay at each end marks by the current passing through the relays and upper resistance coils by reason of the difference of potential produced by each battery through its own lower duplex resistance coil.

The bridge duplex permits the application of signalling and reading condensers, and the minimum amount of retardation is introduced in the path of the sending circuit. This results in a higher speed of working on long underground or cable circuits at the expense of higher battery power, but it possesses on circuits not worked at high speed no advantage over the differential duplex, and on the contrary has the disadvantage of the higher power required to work it.*

UNIVERSAL BATTERY SYSTEM

The provision of a separate primary battery for each circuit in a large telegraph office is very costly, and considerable saving is effected by substituting a secondary cell installation. The cells are usually charged by a motor generator, the current required to run it being obtained from the town electricity supply. It is found that voltages of 24, 40, 80 and 120 meet practically all cases, but where a higher voltage is required for a particular circuit primary cells to the required additional voltage are added to the 120v. lead. Voltages in excess of 120 + and - should not be employed on aerial circuits on account of the danger to workmen employed on overground pole lines. Since both positive and negative currents are required, two earthed batteries are necessary for each voltage supplied, and the keys of the sending apparatus must be modified so as to select either the positive or negative voltage instead of to reverse the connections of the battery between line and earth. Every single needle, double-plate sounder and doublecurrent circuit therefore requires both positive and negative voltages.

The total current required determines the size of the cells, which is stated in terms of ampere-hours. The time during which each circuit in the office is working is multiplied by the total current required, and the sum of these estimates gives the ampere-hours demanded of the cells on each voltage. As the cells may, in the event of a fault, cause large currents to flow, fuses consisting of fine wire are inserted as shown in Fig. 22. In this way fire risks and injury to the cells as the result of an excessive discharge current are avoided.

The 24v battery is duplicated so that the spare sets may be charged while the other sets are in use. In the case of the main battery only one 20-cell spare

* "Bridge" working is more fully described and applied in Pamphlet B.3 "Wheatstone System."

set for positive, and one 20-cell set for negative voltages are provided. The inner 40v set of cells provides current for circuits using 40v; 80v and 120V ;

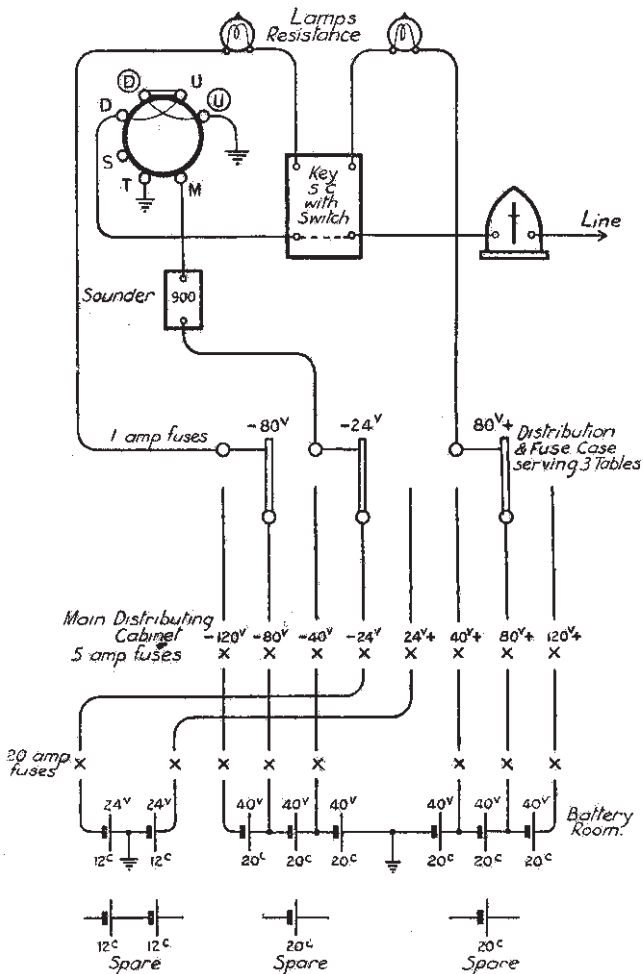

Fig. 22.

the next set for circuits using 80v and 120v, whilst the outer set supplies current only for circuits using 120v, hence the three sets composing either

positive or negative voltages are unequally worked. To render their discharge more uniform the cells are, by a rotary switch, changed in position each day. The first change replaces the inner set by the spare set which has just been charged, the 40v battery takes the place of the 80v battery, the 80v of the 120v and the 120v of the spare battery and is then charged up. At the end of four days each set of cells has occupied the positions of each voltage and has been charged. In the case of universal telegraph battery switching arrangements other than those referring to rotary switch equipment the ampere hour capacity of the cells required has to be calculated on a basis different from that indicated in the foregoing paragraphs. (See PW-G4).

The 20 ampere fuses placed at the cells protect the leads to the Main Distributing Cabinet, and a fault, such as a failure of insulation between the cells and the cabinet, blows this fuse if the current reaches 20 amperes. At the cabinet the 5 ampere fuses guard against faults in the leads and "Distribution and Fuses cases" on the instrument tables—a case being placed on the centre table of the three which it serves. In this case each power lead to each set is protected by a 1 ampere fuse, so that a fault on the leads, or in the apparatus of a set, blows only the fuse in connection with that set, and does not affect the other circuits using that particular voltage. On circuits using line voltages of less than 80, in order to reduce the trouble caused by blowing of the 1 ampere fuses by any ordinary line fault, and also to prevent excessive sparking on long high speed circuits, a metal-cased resistance of approximately 2 ohm per volt used is inserted in each lead at each of the battery terminals of the key, thus reducing the current supplied to half an ampere in the event of even a dead earth at the key. Where 80 volts or 120 volts are used glow lamps are inserted as protective resistances in place of the coils.

Battery power for the local circuit is provided by the 24v leads, and the office is divided into two sections, half being supplied from the 24v positive and half from the 24v negative. The sounders are wound to a resistance of 900Ω and the tongue of the relay merely connects the sounder to earth—in this way the sounder takes the places of the resistance coils inserted in the line battery leads.

Alterations to Apparatus Connections - The principle of the changes consists first in arranging that the key shall on a double-current circuit join either the positive or the negative voltage to line according to its position. The S.C. key with switch (Fig. 23) provides for this; with the switch at "send" and the key at rest, joins positive to the lower right terminal, but when depressed so connects negative. With the switch at "receive" the line is joined

through to the relay. Since reversal of line and earth cannot be effected in the case of down stations, it is necessary -

- (i) to reverse the line battery leads,
- (ii) to reverse the D and U-circle connections of the relay.
- (iii) to reverse the connections of the galvanometer.

Changes (i) and (ii) are shown in Fig. 23, which should be compared with the upper part of Fig. 22, where the connections of an up station are represented.

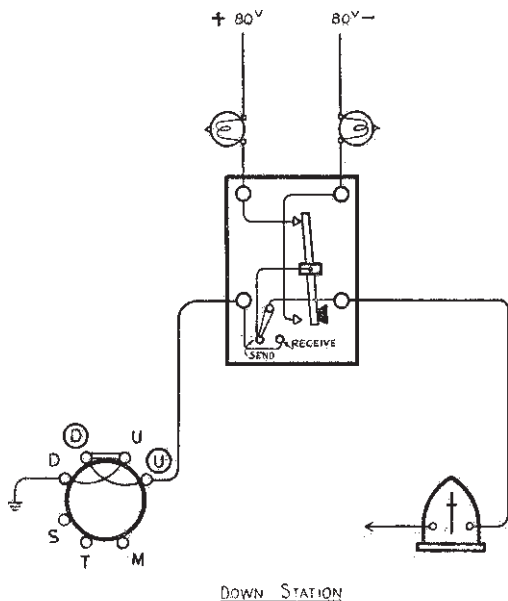

Fig. 23.

As the internal resistance of a secondary battery is negligible, the current does not appreciably vary in any given circuit, whether that circuit only is sending out a current or whether a large number of the other circuits connected to the voltage used are also sending. For example, the current sent out on a circuit having a total resistance of $2,000\Omega$ (including the M.C. resistance coil) by the 40v lead is 20 m.a. If now 19 other circuits of like resistance

also turn their switches to send each circuit will have a current of 20 m.a., because the joint resistance of the group is now $2,000/20 = 100\Omega$, and the total current from 40v is therefore 400 m.a. or 20 m.a. per circuit. With primary cells the internal resistance would be appreciable, and large variations of current would occur; hence primary cells should only be used to supply small groups of circuits-not usually exceeding six, and the internal resistance of the battery should not exceed half the joint resistance of all the circuits connected to it.

CENTRAL BATTERY TELEGRAPHS

The Central Battery system obviates the necessity for batteries at the out-stations, thus enabling considerable savings to be effected in the mainte-

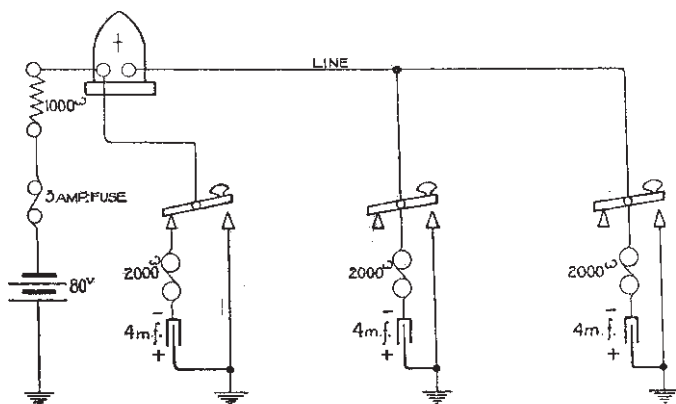

Fig. 24.

nance cost of the service. The arrangement of a 3-station circuit is shown in Fig. 24. The negative end of an earthed 80-volt battery is applied through a "feed" resistance of $1,000\Omega$ to the line. At the out stations a $2,000\Omega$ polarized sounder and a 4-m.f. condenser are connected to the line. At the Head Office similar apparatus is joined to line through a S.C. galvanometer and the back contact of the key. The condensers are normally charged to a difference of potential of 80 volts, When the line is earthed by the depression of any of the keys (except at the Head Office) the sounders and condensers are short-circuited, and each condenser discharges through its sounder (which must be adjusted to the neutral condition) and this produces a mark. When the Head Office key is depressed the home sounder is not actuated; but the out office

instruments respond as already described. When the key is allowed to rise the condensers are again charged through the sounders, and this momentary current causes the sounder armatures to be returned to the normal or spacing condition.

Central Battery Duplex - A Central Battery Duplex circuit can be obtained by application of the underlying principles of the decrement quadruplex.* At the Head Office the connections required are similar to those of an ordinary doublecurrent duplex, save that the polarized relay is replaced by a non-polarized relay. At the out-station a single-current key is employed,

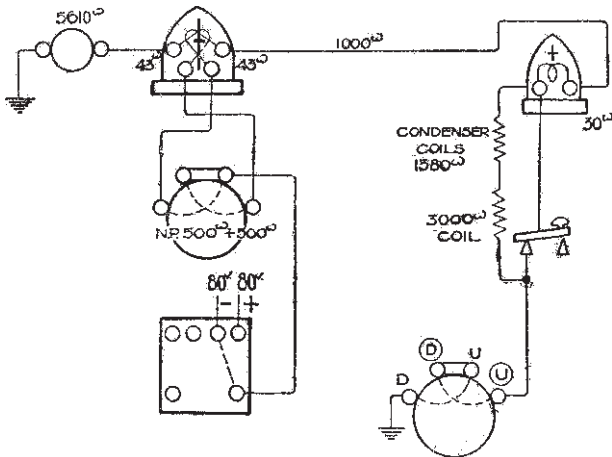

Fig. 25.

and when depressed it introduces a fairly high resistance into the circuit of the polarized relay which is joined to line. With the out-station's key at rest the circuit is unbalanced, more current passing to line than through the compensation circuit. The spring on the armature of the N.P. relay at the Head Office tends to pull the tongue of the relay to the marking stop, but this tendency is overpowered by the excess of current passing to line. When the out-station's key is depressed, equal currents pass through the two windings of the N.P. relay at the Head Office: the circuit now being balanced, the spring is free to act and the tongue passes to the marking stop. The signals at the out station are controlled by the key at the Head Office, i.e., by the direction of

*See pamphlet B.4, "Quadruplex."

the current sent out. Its value is determined by the position of the single current key, but it is ensured that with the key depressed the volume of the current is sufficient to produce satisfactory signals. The skeleton connections are indicated in Fig. 25.

THE WHEATSTONE A.B.C.

The principal advantage of the A.B.C. is that anyone can be taught to operate it in half an hour, but, owing to its complexity, it is costly to provide and to maintain, and it is, wherever possible, being replaced by a telephone. The electrical energy required for its operation is obtained by turning the handle of the communicator continuously whilst sending a message. The communicator consists of a magnetogenerator with an arrangement by which a pre-determined number of current impulses maybe sent out. A key is provided

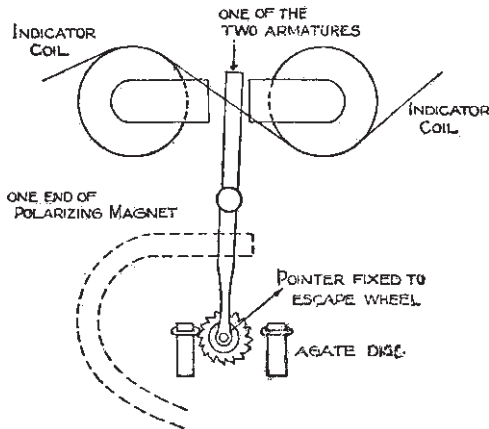

Fig. 26.

for each letter or character, and the position of the key depressed determines the number of current waves sent out, and this controls the position of the pointer at the distant end of the circuit. The indicator and bell are combined in one piece of apparatus. The indicator bears considerable resemblance to a standard relay, being provided with two soft iron armatures rendered magnetic by the horseshoe magnet placed behind them (Fig. 26). The tongue of the instrument, however, bears a small toothed wheel, and as the tongue moves from side to side the toothed wheel is revolved to the extent of a single tooth. This toothed wheel is connected to a pointer which travels over the face of the dial, on the edge of which the various letters and characters are engraved.

The escape wheel is provided with 15 teeth, and 30 motions are therefore required to effect a complete revolution. The pointer may be caused to travel to any one of the 30 characters on the dial by sending out a suitable number of current impulses which alternate in direction.

The communicator is furnished with 30 keys arranged around the dial. The characters on the dial correspond with those on the indicator, and signalling is effected by depressing the keys in the order in which the letters occur in the words to be signalled. The completion of a word is indicated by pausing at zero. The pointer of the communicator is arrested at the point where the key is depressed, and is released immediately a second key is put down. The depression of the second key restores the first one to the normal position by

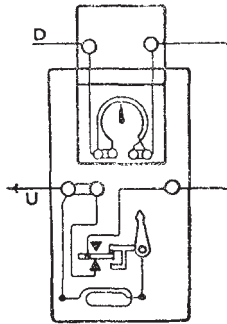

Fig. 27.

means of an endless chain, which is of sufficient length only to permit one key to be depressed at a time. The armature of the generator is geared to the pointer and to a contact arm in such a way that a complete revolution of the pointer over the 30 characters corresponds to 15 complete revolutions of the armature. The contact arm and pointer are, however, capable of being arrested by a depressed key. Immediately the contact arm is arrested the circuit of the generator is disconnected, and in this way the correct number of current impulses is sent out, e.g., from zero to the letter G on the indicator 7 current impulses are transmitted: the generator is then disconnected. If now the O key be depressed the contact arm is released, the generator joined up, and 8 more current impulses are sent out. At this point the contact arm is again arrested and the generator disconnected. The connections of the set are shown in diagrammatic fashion in Fig. 27.

The standard method of working A.B.C. circuits is on the leak method with condensers placed in series with the indicators. This arrangement, by nullifying the effects of the self-induction of the apparatus, enables a larger number of offices to be worked on one circuit, and also eliminates the effects of leakage currents from earth.

It is possible to obtain a written record of the message by substituting a Steljes recorder for the indicator. The messages are printed in Roman characters upon a tape. The number of currents sent out by the communicator determines the position of the type wheel in a fashion somewhat similar to that in which the movement of the A.B.C. indicator needle is controlled. The electro-magnet which determines the printing of the letter is placed in series with the escapement electro-magnet, and is permanently attracted whilst the pointer of the communicator is in motion, and is released only when the series of currents between the various letters signalled is ended. The moment the current ceases the tape is brought into contact with the inked type wheel; the character is thereby recorded and the tape moved forward ready for printing the next character.

LIST OF

Technical Pamphlets for Workmen.

(Continued)

GROUP D - *continued.*

18. Distribution Cases, M.D.F. and I.D.F.
19. Cord Repairs.
20. Superposed Circuits. Transformers. Bridging Coils and Retardation Coils.
21. Call Offices.
22. Units Amplifying (*Not on sale*)

GROUP E.

1. Automatic Telephony: Step by Step Systems.
2. Automatic Telephony:- Coder Call Indicator (C.C.I.) Working.
3. Automatic Telephony: Keysending "B" positions.

GROUP F.

1. Subscribers' Apparatus. Common Battery System.
2. Subscribers' Apparatus. C.B.S. Part I-C.B.S. No. 1 System.
3. Subscribers' Apparatus, Magneto.
4. Private Branch Exchanges-Common Battery System.
5. Private Branch Exchanges--C.B. Multiple, No. 9.
6. Private Branch Exchanges - Magneto 7. House Telephones.
8. Wiring of Subscribers' Premises.

GROUP G.

1. Maintenance of Secondary Cells.
2. Power Plant for Telegraph and Telephone Purposes.
3. Maintenance of Power Plant for Telegraph and Telephone Purposes.
4. Telegraph Battery Power Distribution Boards.

GROUP H.

1. Open Line Construction, Part I.
2. Open Line Construction, Part II.
3. Open Line Maintenance.
4. Underground Construction, Part I - Conduits.
5. Underground Construction, Part II - Cables.
6. Underground Maintenance.
7. Cable Balancing.
8. Power Circuit Guarding.
9. Electrolytic Action on Cable Sheaths, etc.
10. Constants of Conductors used for Telegraph and Telephone Purposes.

GROUP I.

1. Submarine Cables.

GROUP K.

1. Electric Lighting.
2. Lifts.
3. Heating Systems.
4. Pneumatic Tube Systems.
5. Gas and Petrol Engines.